

# R&S<sup>®</sup>ESR-K55

## Real-Time Analysis

### User Manual



1175.7074.02 – 04

This manual applies to the following R&S®ESR options:

- R&S®ESR-K55 (Realtime Analysis)

The contents of this manual correspond to the following R&S®ESR models with firmware version 1.78SP1 or higher:

- R&S ESR3
- R&S ESR7

© 2013 Rohde & Schwarz GmbH & Co. KG

Mühlhofstr. 15, 81671 München, Germany

Phone: +49 89 41 29 - 0

Fax: +49 89 41 29 12 164

E-mail: [info@rohde-schwarz.com](mailto:info@rohde-schwarz.com)

Internet: [www.rohde-schwarz.com](http://www.rohde-schwarz.com)

Printed in Germany – Subject to change – Data without tolerance limits is not binding.

R&S® is a registered trademark of Rohde & Schwarz GmbH & Co. KG.

Trade names are trademarks of the owners.

The following abbreviations are used throughout this manual: R&S®ESR is abbreviated as R&S ESR.

# Contents

<b>1</b>	<b>Measurement Modes.....</b>	<b>5</b>
1.1	Receiver Mode.....	5
1.2	Spectrum Mode.....	5
1.3	I/Q Analyzer Mode.....	6
1.4	Real Time Mode.....	6
1.5	Measurement Mode Root Menus (HOME Key).....	6
<b>2</b>	<b>Measurements and Result Displays.....</b>	<b>7</b>
2.1	The Realtime Spectrum Result Display.....	7
2.2	The Spectrogram Result Display.....	9
2.3	The Persistence Spectrum Result Display.....	21
<b>3</b>	<b>Measurement Basics.....</b>	<b>29</b>
3.1	Data Acquisition and Processing in a Realtime Analyzer.....	29
3.2	Configuring Realtime Measurements.....	31
3.3	Triggering Measurements.....	34
3.4	Using Markers.....	40
3.5	Detector Overview.....	43
3.6	ASCII File Export Format.....	43
<b>4</b>	<b>Configuration.....</b>	<b>45</b>
4.1	Result Display Selection.....	45
4.2	Result Display Configuration.....	46
4.3	Common Measurement Settings.....	48
<b>5</b>	<b>Analysis.....</b>	<b>60</b>
5.1	Working with Traces.....	60
5.2	Using Markers.....	63
<b>6</b>	<b>Remote Control Commands.....</b>	<b>70</b>
6.1	Selecting the Operating Mode.....	70
6.2	Measurements and Result Displays.....	71
6.3	Configuration.....	83
6.4	Analysis.....	103
6.5	Status Registers.....	139

**List of Commands.....148**  
**Index.....153**

# 1 Measurement Modes

The R&S ESR provides several measurement modes for different analysis tasks. When you activate a measurement mode, a new measurement channel is created. The channel determines the settings for that measurement mode. Each channel is displayed in a separate tab on the screen.

SCPI command:

`INSTRument[:SElect]` on page 71

## To change the measurement mode

1. Press the MODE key.  
A menu with the currently available measurement modes is displayed.
2. To activate a different mode, press the corresponding softkey.

## 1.1 Receiver Mode

In Receiver mode, the R&S ESR measures the signal level at a particular frequency. It also provides tools (e.g. detectors or bandwidths) necessary to measure the signal according to EMC standards. The Receiver mode is the default mode of the R&S ESR.

The R&S ESR also provides function for IF analysis if you have equipped your R&S ESR with firmware application R&S ESR-K53. IF analysis is not a separate measurement mode but is integrated into the Receiver mode.

For more information on functionality available for the Receiver mode see the documentation of the R&S ESR.

SCPI command:

`INST REC`

## 1.2 Spectrum Mode

In Spectrum mode the provided functions correspond to those of a conventional spectrum analyzer. The analyzer measures the frequency spectrum of the RF input signal over the selected frequency range with the selected resolution and sweep time, or, for a fixed frequency, displays the waveform of the video signal.

The Spectrum mode also provides spectrogram measurements. The spectrogram is not a separate measurement mode, but rather a trace evaluation mode. Note also that the Spectrogram available in Spectrum mode is independent of that available in real time mode. It provides similar functionality but uses different data acquisition methods.

For more information on functionality available for the Receiver mode see the documentation of the R&S ESR.

SCPI command:

`INST SAN`

### 1.3 I/Q Analyzer Mode

The I/Q Analyzer mode provides measurement and display functions for digital I/Q signals.

For more information on functionality available for the Receiver mode see the documentation of the R&S ESR.

### 1.4 Real Time Mode

In Real Time mode, the R&S ESR performs measurements in the frequency spectrum of a test signal without losing any signal data. You can evaluate the measurement results in several result displays that are designed for the realtime analysis and complement one another.

Real Time analysis is available with firmware application R&S ESR-K55 and hardware option R&S ESR-B50.

SCPI command:

`INST RTIM`

### 1.5 Measurement Mode Root Menus (HOME Key)

The HOME key provides a quick access to the root menu of the current measurement mode.

## 2 Measurements and Result Displays

The R&S ESR, when operated in realtime mode has several result displays. You can select a result display with one of the softkeys in the "Home" menu that you can access via the  key. An alternative way to configure the display is the "Display Configuration" dialog box that you can open with the "Display Config" softkey.

The dialog box has four tabs (Screen A through D) to configure up to four result displays. In the default state, Screen A and Screen B are active and show the realtime spectrum and the spectrogram respectively. You can, however, customize the display of the R&S ESR as you like.

You can add or remove a result display by checking or unchecking the "Screen Active" item and define the corresponding result display with the radio button below.

The "Predefined" tab contains customized screen layouts. Some of those are already provided with the firmware. You can also add your own screen layouts to the list in order to avoid configuring the screen every time you start the R&S ESR.

The "Add" button adds a new screen layout to the list. Pressing the "Apply" button applies the screen layout you have selected and the "Remove" button removes the selected layout from the list. If you want to restore the default configurations, press the "Restore" button.

[CALCulate<n>:FEED](#) on page 72

- [The Realtime Spectrum Result Display](#).....7
- [The Spectrogram Result Display](#).....9
- [The Persistence Spectrum Result Display](#).....21

### 2.1 The Realtime Spectrum Result Display

In principle, the realtime spectrum result display looks just like the result display of a conventional spectrum analyzer. It is a two-dimensional diagram that contains a line trace that shows the power levels for each frequency for a particular bandwidth or span with the horizontal and vertical axis representing frequency and amplitude. The big difference to a conventional spectrum analyzer is the way the realtime spectrum analyzer gets its data.

[CALCulate<n>:FEED](#) on page 72

#### Displaying the data

The evaluation of the final displayed results again is standard spectrum analyzer functionality. The R&S ESR combines a spectrum consisting of 801 measurement points and adjusts them to the number of pixels that the display has. The way it evaluates the final results that you see on the display, depends on the type of detector that you have set.

For more information refer to [chapter 3.5, "Detector Overview"](#), on page 43.

As the number of FFTs is considerably higher than the sweep time, the R&S ESR combines several FFTs in one trace. The number of FFTs combined in a trace at a bandwidth of 40 MHz depends on the sweep time and is according to the following formula.

$$N = \text{SweepTime}[\text{sec}] \cdot 250.000 \left[ \frac{\text{FFT}}{\text{sec}} \right]$$

### 2.1.1 Screen Layout of the Realtime Spectrum Result Display

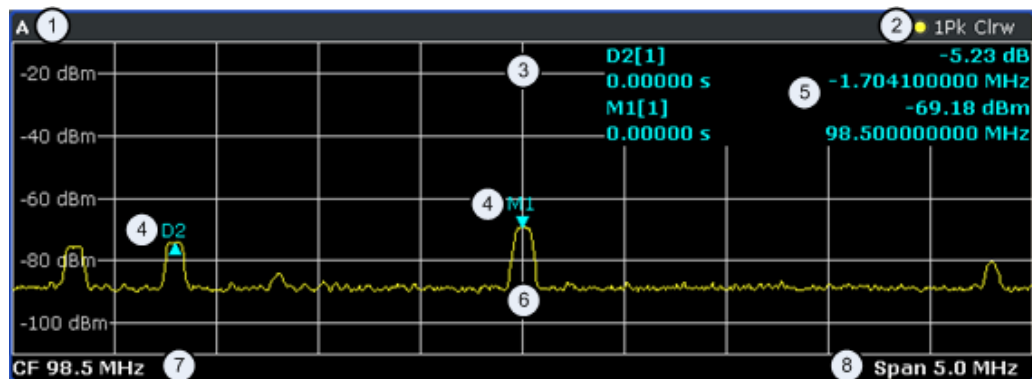

- 1 = Window number: shows the window of the result display (A through D)
- 2 = Trace information: includes trace mode and detector
- 3 = Trace diagram
- 4 = Markers: Mx for normal markers and Dx for deltamarkers
- 5 = Marker information: trace number, marker frequency and corresponding amplitude
- 6 = Realtime trace (yellow line)
- 7 = Center frequency
- 8 = Span

### 2.1.2 Applications of the Realtime Spectrum

Just like the spectrum results of a conventional analyzer, you can find many applications for the realtime spectrum result display.

If you use it as a standalone result display, the advantage of the realtime spectrum result display is the ability to monitor the spectrum without losing information.

The best way to use this feature, however, is to combine the realtime spectrum result display with the spectrogram result display in split screen mode. The spectrogram shows the results with a large history depth, but is not suited for detailed analysis of the data. You can, however, select a particular frame in the spectrogram's history with the marker and recall the spectrum of that frame for further and more detailed and full analysis of the measured signal.

The picture below shows that application. The realtime spectrum is not the currently measured spectrum, but the one that was measured at the time of marker 1. The realtime spectrum corresponds to the spectrogram frame of the marker position.



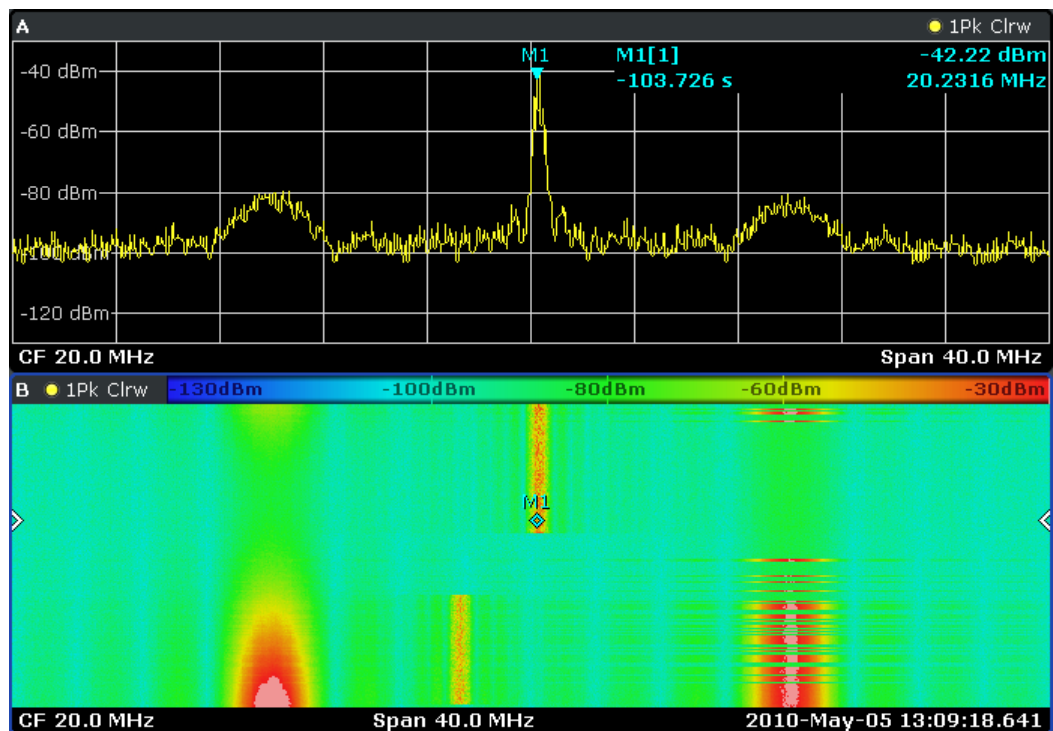

Fig. 2-1: Simultaneous display of realtime spectrum and spectrogram showing a past spectrum

## 2.2 The Spectrogram Result Display

The spectrogram result display shows the spectral density of a signal in the frequency domain and over time simultaneously. It provides an overview of the spectrum over time and so allows for an easy detection of anomalies and interfering signals.

Like the realtime spectrum, the horizontal axis represents the frequency span. The vertical axis represents time. Time in the spectrogram runs chronologically from top to bottom. Therefore, the top of the diagram is the most recently recorded data. The spectrogram also shows the power levels for every realtime spectrum trace. To display the level information, the R&S ESR maps different colors to each power level that has been measured. The result is therefore still a two dimensional diagram.

[CALCulate<n>:FEED](#) on page 72

The process to get the spectrogram result display is as follows:

- capturing the data from the realtime trace
- coloring the results.
- processing the data

The stages occur at the same time.

### Capturing the data

The spectrogram uses the realtime spectrum traces as its data basis. The data capture process is therefore the same as that of the realtime spectrum result display.

For more information, see [chapter 3.1, "Data Acquisition and Processing in a Realtime Analyzer"](#), on page 29

After the data has been captured, the R&S ESR transforms the data of the realtime spectrum into the spectrogram result display.

### Coloring the results

To get the final looks of the spectrogram, the R&S ESR applies colors to visualize the power levels in a two dimensional diagram.

Each color in the spectrogram corresponds to a particular power level that is shown in the color map in the title bar of the result display. The color the R&S ESR assigns to each power level depends on:

- the color scheme you have selected
- the (customized) color mapping settings

In the default configuration, the R&S ESR displays low power levels in 'cold' colors (blue, green etc.) and higher power levels in 'warm' colors (red, yellow etc.).

For more information, see [chapter 2.2.3.3, "Customizing the Color Mapping"](#), on page 16

### Displaying the results

Now that the data is available, the R&S ESR processes the data to display it in the spectrogram result display.

To understand the structure and contents of the spectrogram, it is best to activate the realtime spectrum result display in combination with the spectrogram, as the data that is shown in the spectrogram is always based on the data of the trace in the realtime spectrum result display.

The spectrogram is made up out of a number of horizontal lines, each one pixel high, that are called (time) frames. Like the trace of the realtime spectrum, a spectrogram frame contains several FFTs. The exact number of FFTs contained in a frame depends on the sweep time. As the sweep time also sets the length of a realtime spectrum trace, by default a frame in the spectrogram always corresponds to exactly one trace in single sweep mode in the realtime spectrum result display. You can change this ratio by changing the sweep count.

In the default state, a frame is added to the spectrogram after each sweep. As the spectrogram in the R&S ESR runs from top to bottom, the outdated frame(s) move down one position, so that the most recently recorded frame is always on top of the diagram.

The number of frames the R&S ESR can display simultaneously is only limited by the vertical screen size. The number of frames the R&S ESR stores in its history memory is bigger. It depends on the history depth you have set, with the maximum being 100.000. You can then navigate to any of the frames stored in the history buffer.



Note that the R&S ESR stores just the trace information in its memory, not the I/Q data itself.

For more information, see [chapter 2.2.3.1, "Working with the Spectrogram History"](#), on page 12.

By default, the currently shown realtime spectrum trace corresponds to the spectrogram frame that has been recorded last. In single sweep mode, you can, however, recall the spectrums up to a maximum of 100.000 frames and evaluate them at a later time. The number of spectrums available depends on the history depth.

## 2.2.1 Screen Layout

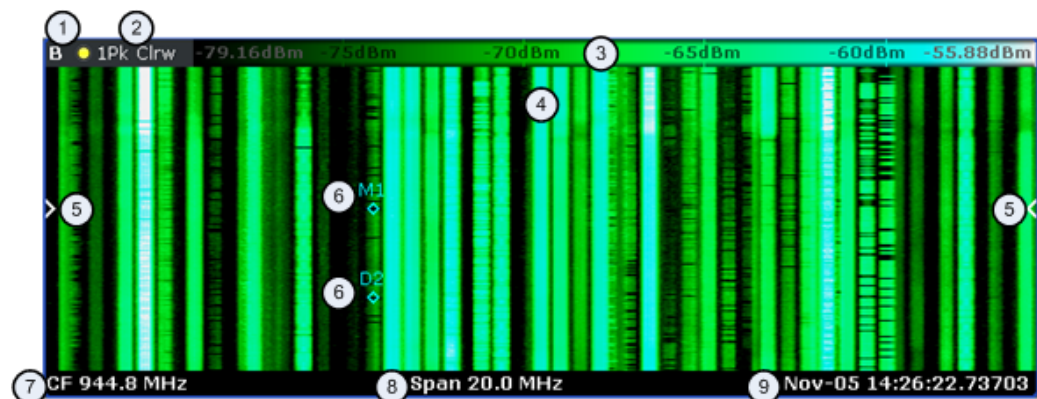

- 1 = Window number: shows the window of the result display (A through D)
- 2 = Trace information: includes trace mode and detector
- 3 = Color Map
- 4 = Spectrogram
- 5 = Marker indicator: shows the vertical position of the active marker
- 6 = Markers and deltamarkers
- 7 = Center frequency
- 8 = Span
- 9 = Time stamp information; if time stamp is inactive this shows the currently active frame instead

## 2.2.2 Applications of the Spectrogram Result Display

The spectrogram provides an easy way to monitor the changes of a signal's frequency and amplitude over time. Typically, it is used for measurements in which time is a factor. However, there are a lot of applications you could think of.

A typical applications of a spectrogram is the monitoring of telecommunications systems that are based on frequency hopping techniques, e.g. GSM. Using the spectrogram, you can see at a glance whether slots are allocated correctly or not. In addition, the result display also provides information on the time a particular channel is in use.

Again in telecommunications systems that use frequency hopping techniques, you can use the spectrogram to monitor the settling time to a new frequency after the channel switching.

The spectrogram is also suited for more general measurement tasks like measuring the settling time of a DUT or the detection of the time and statistical frequency of interfering signals.

## 2.2.3 Configuring the Spectrogram

The spectrogram has two distinctive features: information over a period of time and the colors. That means that it is important that you can customize various things concerning these two features.

[TRACe<n>\[:DATA\]](#) on page 107

[MMEMory:STORe:SGRam](#) on page 81

### 2.2.3.1 Working with the Spectrogram History

In realtime mode, the spectrogram provides a record of the spectrum without gaps. Because the R&S ESR stores the history of the spectrum in its memory, you can analyze the data in detail at a later time by recalling one of the spectrums in the spectrogram history.

#### Defining the History Depth

The "History Depth" softkey defines the number of frames that the R&S ESR stores in its memory. The maximum history depth is 100.000 frames.

It is possible to recall the realtime traces to any of the frames that the R&S ESR has in its memory.

For more information, see

- [chapter 2.1.2, "Applications of the Realtime Spectrum"](#), on page 8
- [chapter 2.2.2, "Applications of the Spectrogram Result Display"](#), on page 11
- [CALCulate<n>:SGRam:HDEPth](#) on page 79

#### Defining a Frame Count

The frame count defines the number of traces the R&S ESR plots in the spectrogram result display in a single sweep. The maximum number of possible frames depends on the history depth.

The sweep count, on the other hand, determines how many sweeps are combined in one frame in the spectrogram, i.e. how many sweeps the R&S ESR performs to plot one trace in the Spectrogram result display.

You can set the frame count with the "Frame Count" softkey which is available in single sweep mode.

[CALCulate<n>:SGRam:FRAMe:COUNT](#) on page 78

### Selecting a Frame

To get more information, you can select any frame that is stored in the memory of the R&S ESR with the "Select Frame" softkey. Depending on whether you have activated a time stamp or not, you select the frame either by time in seconds from the most recent recorded frame (time stamp On) or by directly entering the frame number you'd like to see (time stamp Off).

To select a specific frame, the R&S ESR has to be in single sweep mode.

`CALCulate<n>:SGRam:FRAMe:SElect` on page 78

### Using the Time Stamp

The time stamp shows the time information of the selected frame. The length of one frame corresponds to the sweep time.

If the time stamp is active, the time stamp shows the time and date the selected frame was recorded. To select a specific frame, you have to enter the time in seconds, relative to the frame that was recorded last. An active time stamp is the default configuration.

If you deactivate the time stamp with the "Time Stamp (On Off)" softkey, the time information is an index. The index is also relative to the frame that was recorded last, which has the index number 0. The index ends with a negative number that corresponds to the history depth. To select a specific frame, you have to enter the index number of the frame you want to analyze.

`CALCulate<n>:SGRam:TSTamp[:STATe]` on page 80

`CALCulate<n>:SGRam:TSTamp:DATA?` on page 79

### Exporting the Spectrogram Data

The R&S ESR allows you to export the spectrogram data to an ASCII file.

When you export the spectrogram to an ASCII file, the R&S ESR writes the complete contents in its memory to an ASCII file. The amount of data depends on the [history depth](#).

To export the spectrogram, the spectrogram window has to be in focus (blue frame). To perform the export itself, use the "ASCII Trace Export" softkey in the "Trace" menu.



#### File size

Depending on the contents of the capture buffer, the export may take some time and the size of the ASCII file may be very large.

---

### Clearing the Spectrogram

If you need to restart the spectrogram, you can clear the memory of the R&S ESR with the "Clear Spectrogram" softkey at any time.

It is also possible to clear the spectrogram after each sweep automatically if you are in single sweep mode. You can do so with the "Continue Frame (On Off)" softkey. If it is active, the spectrogram keeps filling up with data after a single sweep. If inactive, however, the R&S ESR clears the spectrogram after every single sweep.

`CALCulate<n>:SGRam:CLEar[:IMMediate]` on page 77

`CALCulate<n>:SGRam:CONT` on page 77

### 2.2.3.2 Zooming into the Spectrogram

For further and more detailed analysis of the data you have captured, the R&S ESR provides a zoom.

The zoom is available for the spectrogram result display, but has effects on other result displays. The spectrogram has to be active and selected (blue border) for the zoom to work.

You can activate the zoom with the  icon and define the zoom area by drawing a rectangle on the touchscreen. When you draw the zoom area, its boundaries are shown as a dashed line. The R&S ESR stops the live measurement and enlargens the area you have defined. The definition of the color map remains the same.

Inside the zoom area, you can use the spectrogram functionality as usual (like frame selection or scrolling through the spectrogram).

For quick comparisons of the zoomed spectrogram and the unzoomed one, you can use the "Replay Zoom (On Off)" softkey in the "Meas" menu.

Zooming into the spectrogram causes the R&S ESR to reprocess and reevaluate the data that has been measured previously and stored in the R&S ESR memory. The zoom also reduces the sweep time and/or resolution bandwidth and span. This in turn improves the resolution of the data (while a graphical zoom merely interpolates the data and thus reduces the resolution).

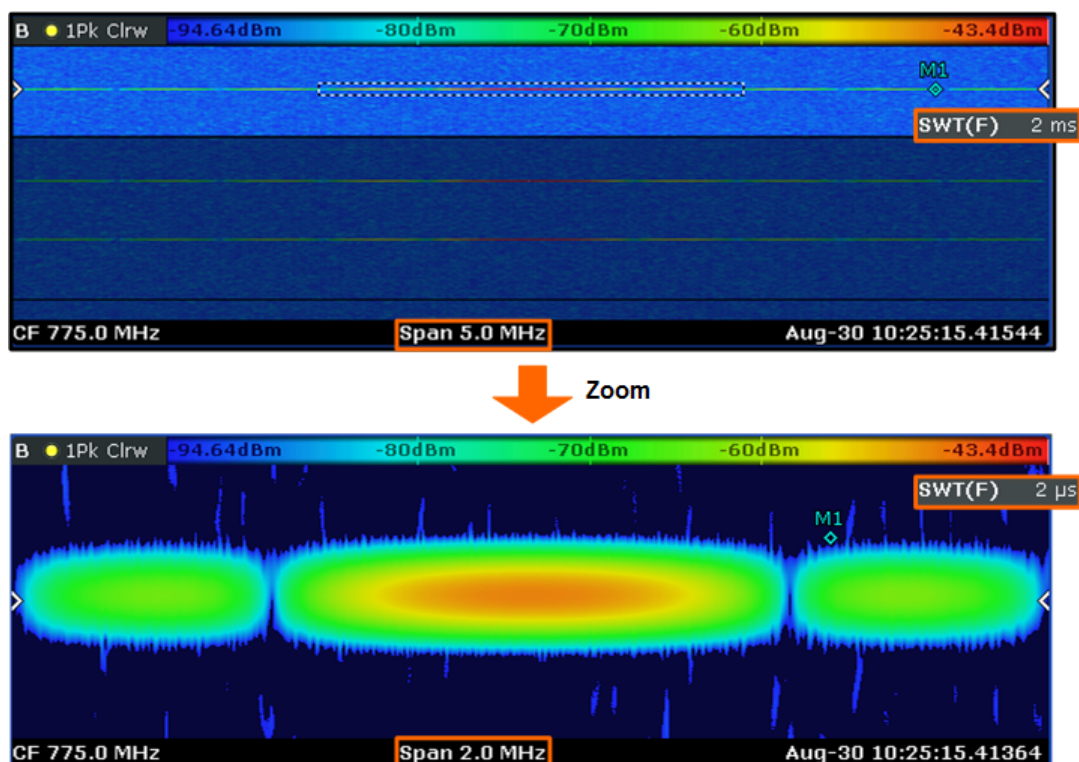



Because the zoom is based on data that has already been captured, the zoom also allows for faster sweep times (and thus spans) than those possible during live measurements (which are limited to 100  $\mu$ s).

As mentioned above, selecting an area in the spectrogram to zoom into changes the sweep time and span (and thus the start and stop frequencies of the diagrams). It may also change the center frequency. The magnitude of the change depends on the size of the zoom area. If the zoom is already active, this mechanism also works the other way round. You can change the zoom factor by changing the sweep time or the span.

### Zoom restrictions

Principally, the zoom is available for all measurement situations, whether you measure continuously, in single sweep mode or use a trigger. However, possible zoom areas are restricted by the size of the memory (4 seconds). If it is not possible to zoom into a spectrogram area, the R&S ESR colors that area in a darker color when you touch it.

The zoom factor is restricted to 10% of the original span of the frequency axis.

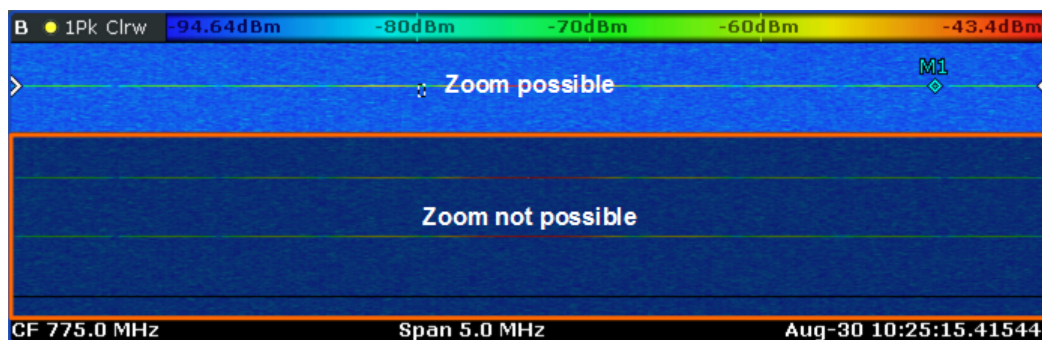

In addition, the zoom is also restricted by the original bandwidth or span you have set. Zooming into areas that are outside this bandwidth is not possible.

Note also that zoom availability depends on the trigger mode. Zooming while the measurement is running is possible only in Free Run mode. For all other trigger modes, you have to wait until the measurement is paused.

### Effects on other result displays

Zooming has an effect on the realtime spectrum result display. All other result displays are unaffected.

- The R&S ESR updates the range of horizontal axis of the realtime spectrum according to the zoomed (new) spectrogram span. The range has an effect on the start, stop and center frequency as well as the span. The realtime spectrum still shows the spectrum of the currently selected spectrogram frame.

Updates in the result displays only take effect if they have been active while the spectrogram data has been reevaluated.

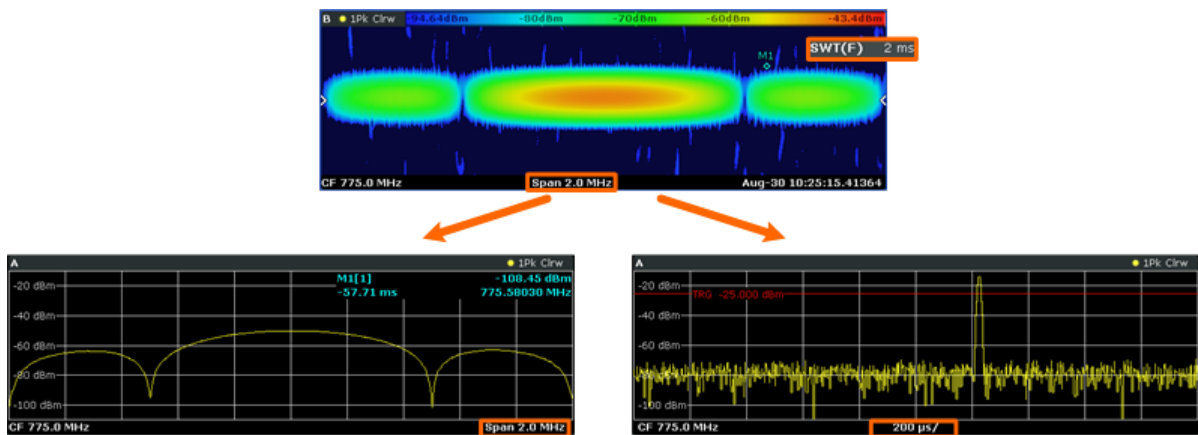

`DISPlay:WINDow[:SUBWindow]:ZOOM:AREA` on page 72

`DISPlay:WINDow[:SUBWindow]:ZOOM:STATE` on page 73

### 2.2.3.3 Customizing the Color Mapping

Colors are an important part of both the persistence spectrum and the spectrogram. Therefore, the R&S ESR provides various ways to customize the display for best viewing results.

You can access the Color Mapping dialog via the "Color Mapping" softkey or by tapping on the color map. The dialog looks and works similar for the histogram and the spectrogram, only the scaling or unit of the color map is different. For the persistence spectrum the R&S ESR maps the colors to percentages, for the spectrogram it maps power levels (dBm). In addition, the dialog box of the persistence spectrum offers a truncate function.



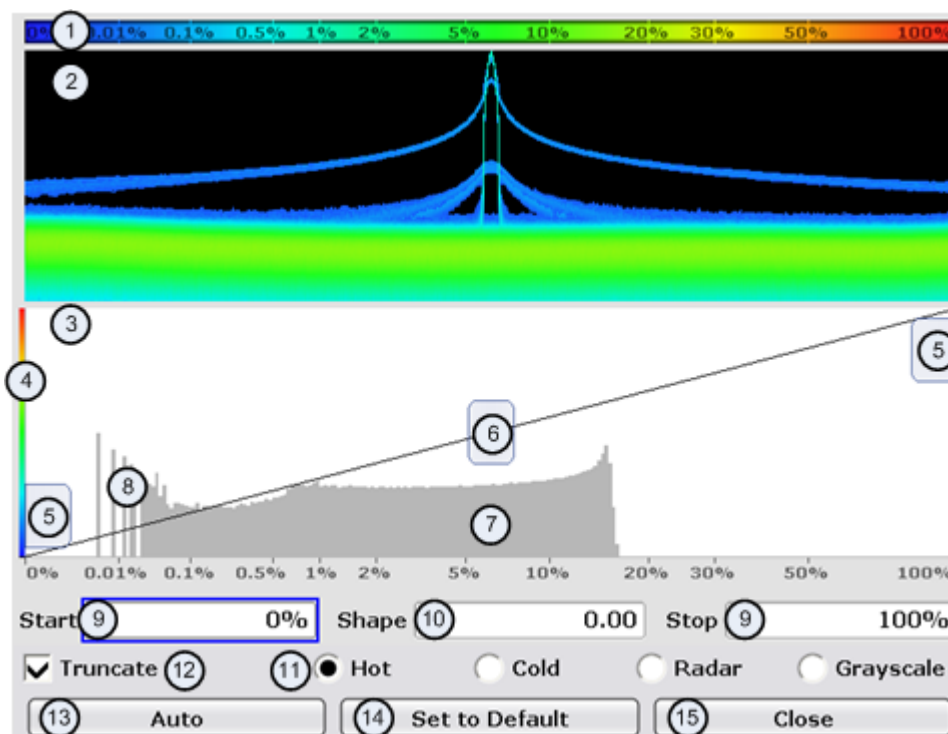

- 1 = Color map: shows the current color distribution
- 2 = Preview pane: shows a preview of the histogram / spectrogram with any changes that you make to the color scheme
- 3 = Color curve pane: graphic representation of all settings available to customize the color scheme
- 4 = Color curve in its linear form
- 5 = Color range start and stop sliders: define the range of the color map; percentages for the histogram or amplitudes for the spectrogram
- 6 = Color curve slider: adjusts the focus of the color curve
- 7 = Histogram: shows the distribution of measured values
- 8 = Scale of the horizontal axis (value range): in the spectrogram this is linear, in the histogram it is the function of the density
- 9 = Color range start and stop: numerical input to define the range of the color map
- 10 = Color curve: numerical input to define the shape of the color curve
- 11 = Color scheme selection
- 12 = Truncate: if active, only shows the results inside the value range; only available for the persistence spectrum
- 13 = Auto button: automatically sets the value range of the color map
- 14 = Default button: resets the color settings
- 15 = Close button: closes the dialog box

### Setting the Color Scheme

Before adjusting the details of the color map, you should select the color scheme you are most comfortable with. You can select from four different color schemes:

- 

The "Hot" color scheme shows the results in colors ranging from blue to red. Blue colors indicate low probabilities or levels respectively. Red colors indicate high ones.

-

The "Cold" color scheme shows the results in colors ranging from red to blue. Red colors indicate low probabilities or levels respectively. Blue colors indicate high ones. The "Cold" color scheme is the inverse "Hot" color scheme.



The "Radar" color scheme shows the colors ranging from black over green to light turquoise with shades of green in between. Dark colors indicate low probabilities or levels respectively. Light colors indicate high ones.



The "Grayscale" color scheme shows the results in shades of gray. Dark grays indicate low probabilities or levels respectively. Light grays indicate high ones.

If a result lies outside the defined range of the color map, it is colored in black at the lower end of the color range. On the upper end of the color range it is always the lightest color possible, regardless of differences in amplitude (e.g. black and blue in case of the "Cold" scheme).

[DISPlay:WINDow:SGRam:COLor\[:STYLE\]](#) on page 82

[DISPlay:WINDow:SGRam:COLor:DEFault](#) on page 81

### Defining the Range of the Color Map

The current configuration could be a color map that you can optimize for better visualization of the measured signal, e.g. if the results cover only a small part of the color map. In the resulting trace, it would be hard to distinguish between values that are close together.

There are several ways to optimize the distribution of the colors over the results and then get the best viewing results.

Note that the following examples are based on the "Hot" color scheme and the spectrogram. Color settings in the histogram are the same with the exception of the unit of the color map that is % in the histogram. If something applies to the spectrogram only, you'll find a note at that place.

The easiest way to adjust the colors is to use the color range sliders in the "Color Mapping" dialog.

In the histogram that is in the background of the color curve pane (grey bars), you can observe the distribution of measurement results. If no significant shifts in result distribution occur after evaluating this for a time, you can adjust the color map to the overall shape of the measurement results. To do so and still cover the whole signal, move the sliders in a way that the first and last bar of the histogram are still inside the range. You can optimize the display further, if you suppress the noise by excluding the lower 10 to 20 dB of the distribution. Note that the color map has to cover at least 10% of the range of the horizontal axis.

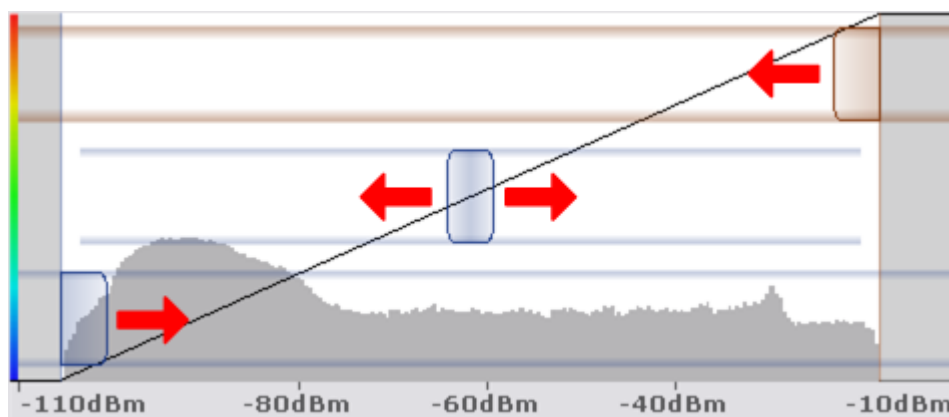

Alternatively, you can set the range in the numeric input field. For the spectral histogram, you enter the percentages as they are plotted on the horizontal axis and displayed in the spectral histogram itself. For the spectrogram however, you have to enter the distance from the right and left border as a percentage.

#### Example:

The color map starts at -100 dBm and ends at 0 dBm (i.e. a range of 100 dB). You, however, want the color map to start at -90 dBm. To do so, you have to enter 10% in the Start field. The FSVR shifts the start point 10% to the right, to -90 dBm.

In the spectrogram, cutting the range as far as possible is also a good way if you want to observe and put the focus on signals with a certain amplitude only. Then, only those signal amplitudes that you really want see are displayed. The rest of the display remains dark (or light, depending on the color scheme). It is also a good way to eliminate noise from the display. In the spectrogram you can do this easily by excluding the corresponding power levels at the low end of the power level distribution.

In the histogram, cutting down the color range is also a good way to eliminate unwanted signal parts. Very frequent level and frequency combinations are most likely noise, so cutting them away means that the color resolution for all other combinations is enhanced and makes it more easy to detect, for example, weak and rare signals.

The persistence spectrum provides an additional truncate function. If active, all values that are outside the color range are no longer displayed in the histogram.

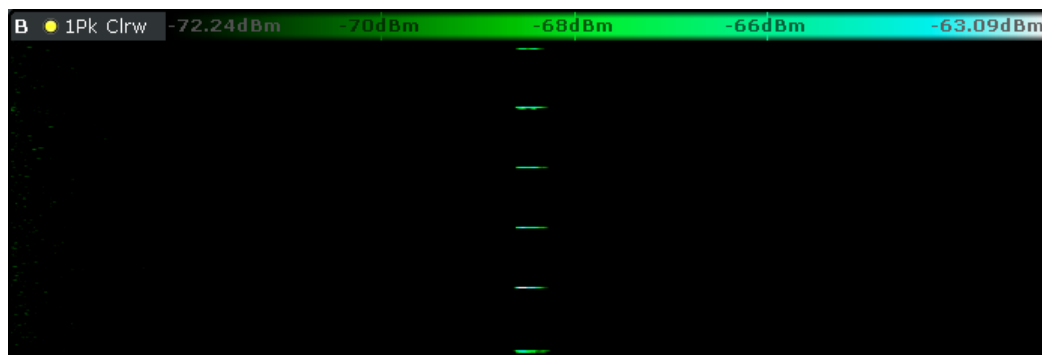

Fig. 2-2: Spectrogram that shows the peaks of a pulsed signal only



### Adjusting the reference level and level range

Changing the reference level and level range also affects the color scheme in the spectrogram.

Make sure, however, that you never adjust in a way that could overload the R&S ESR. For more information, see [AMPT menu](#)

`DISPlay:WINDow:SGRam:COLor:LOWer` on page 81

`DISPlay:WINDow:SGRam:COLor:UPPer` on page 82

### Defining the Shape of the Color Curve

Now that the color scheme and range of the color map suit your needs, you can improve the color map even more by changing the shape of the color curve.

The color curve is a tool to shift the focus of the color distribution on the color map. By default, the color curve is linear. The color curve is linear, i.e. the colors on the color map are distributed evenly. If you shift the curve to the left or right, the distribution becomes non-linear. The slope of the color curve increases or decreases. One end of the color palette then covers a large amount results while the the other end distributes a lot of colors on relatively small result range.

You can use this feature to put the focus on a particular region in the diagram and to be able to detect small variations of the signal.

#### Example:



*Fig. 2-3: Linear color curve shape = 0*

The color map above is based on a linear color curve. Colors are distributed evenly over the complete result range.



*Fig. 2-4: Non-linear color curve shape = -0.5*

After shifting the color curve to the left (negative value), more colors cover the range from -105.5 dBm to -60 dBm (blue, green and yellow). In the color map based on the linear color curve, the same range is covered by blue and a few shades of green only. The range from -60 dBm to -20 dBm on the other hand is dominated by various shades of red, but no other colors. In the linear color map, the same range is covered by red, yellow and a few shades of green.

The result of shifting the color curve is that results in a particular result range (power levels in case of the spectrogram and densities in the case of the spectral histogram) become more differentiated.

You can adjust the color curve by moving the middle slider in the color curve pane to a place you want it to be. Moving the slider to the left shifts the focus in the direction of low

values. Most of the colors in the color map are then concentrated on the low power levels (spectrogram) or densities (histogram), while only a few colors cover the upper end of the color map or high power levels or densities. Moving the slider to the right shifts the focus to the higher amplitudes or densities.

Alternatively, you can enter the shape of the color curve in the corresponding input field below the color curve pane. A value of 0 corresponds to a linear shape, negative values up to -1 shift the curve to the left, positive values up to 1 shift the curve to the right.

[DISPlay:WINDow:SGRam:COLor:SHAPE](#) on page 81

## 2.3 The Persistence Spectrum Result Display

The persistence spectrum is a two dimensional histogram that shows the statistical frequency of any frequency and level combinations for every pixel on the display ('hits' per pixel). As the number of FFTs used to create the histogram is very large, you can also look at it as a probability distribution.

Note that the word 'density' in this context means how frequent a certain level and frequency combination has occurred during the measurement.

In principle, the result display looks just like that of a conventional spectrum analyzer with the horizontal and vertical axis representing the frequency and level respectively. Unlike the trace in a conventional spectrum analyzer, the persistence spectrum includes a third type of information (a virtual z-axis). This virtual axis represents the number of hits that occurred during a particular period of time. This would result in a three dimensional diagram with the height of each bar on the z-axis representing the number of hits per pixel. This makes the result display a (spectral) histogram.

However, in the final display of the results the R&S ESR still shows the trace in two dimensions with the number of hits represented by different shades of color. The result is a trace that covers an area instead of a line trace as you know it from the realtime spectrum result display, for example.

[CALCulate<n>:FEED](#) on page 72

For better orientation, the R&S ESR also always shows the realtime spectrum line trace in the histogram as a white line superimposed over the histogram.



You can turn off the realtime trace by setting the trace mode for that one to "Blank".

To get the final result display for a single frame, the R&S ESR sequentially runs through a number of processing steps:

- collecting the data
- evaluating the data
- calculating relative values of the data
- coloring the results.

The stages occur at the same time.

### Collecting the data

The persistence spectrum that the R&S ESR displays at any time always represents the data it has collected in exactly one frame. That means that in single sweep mode, it shows the data of one frame after it has finished the sweep. The number of FFTs in one frame is variable and depends on the sweep time that you have set. You can calculate the number of FFTs in each frame for a 40 MHz bandwidth with the following formula:

$$N = \text{Granularity}[\text{sec}] \cdot 250.000 \left[ \frac{\text{FFT}}{\text{sec}} \right]$$

### Example:

If you have set a granularity of 0.5 seconds, the number of FFTs that a frame (and the trace) contains is 125.000.

Note that this number refers to the instantaneous histogram. If you work with an active persistence, you can also see the shadows of past histograms on the display. The persistence functionality displays all spectrums that were captured within the persistence time.

For more information on persistence, refer to

- [chapter 2.3.3.1, "Using Persistence"](#), on page 26

### Evaluating the data

After it has collected the data of one frame, the R&S ESR copies all the spectrums included in that frame into the display. If all spectrums were identical, the resulting persistence spectrum would look like a line trace, but in color. However, in reality none of the spectrums looks alike, therefore the fact that many spectrums are on top of each other leads to a diagram that covers a two dimensional area on the screen instead of just a line.

There will be pixels that the spectrum runs through more often than others, whose spectral density is higher than elsewhere. To represent this fact, the R&S ESR copies all spectrums into a virtual table whose dimensions correspond to the resolution of the display with each cell representing one pixel. The horizontal represents the frequency, the vertical axis the amplitude. In the case of the R&S ESR with a resolution of 600x801 pixels, this means that the table would have 480.600 cells. With a full span of 40 MHz and the default display range of 100 dB, one cell would cover about 50 kHz and 0.16 dB.

After the R&S ESR has performed the first FFT and has transferred the corresponding spectrum, the table would, for example, look like this:

The Persistence Spectrum Result Display

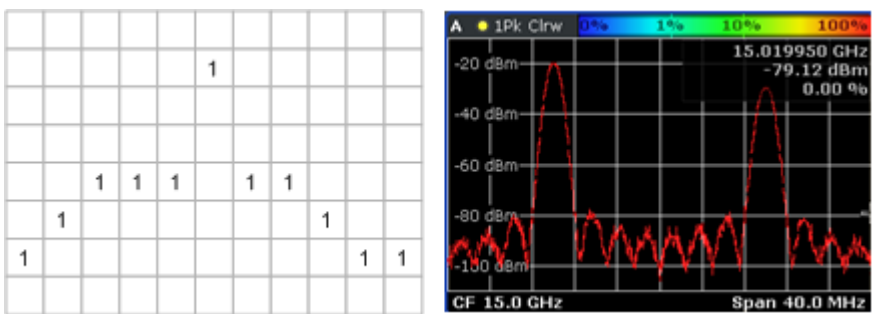

Fig. 2-5: Virtual table and diagram containing the results after one FFT

Since there is only one spectrum and every number in the table represents the number of hits in that cell, each column, at this point, has to contain exactly one value. The sum of each column may not exceed the value '1', as, currently, there is only one spectrum. Additionally, every column must include a number (one for each frequency/ level combination). The display of the trace after this step would look like a line trace.

But as the frame consists of more than one spectrum, the R&S ESR accumulates all spectrums it has captured. Let's assume a frame consists of 10 spectrums. After a single sweep, the table would, for example, look like this:

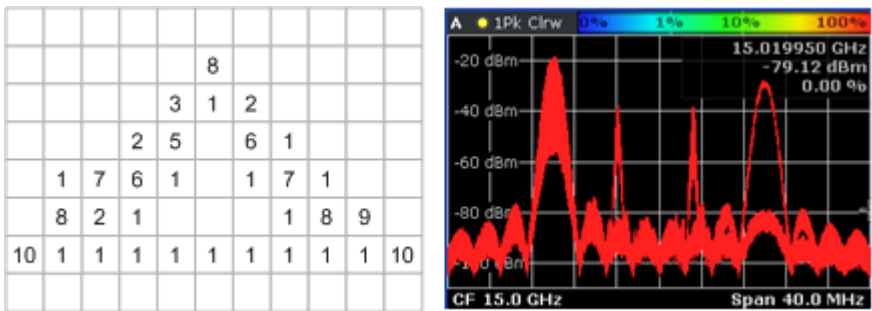

Fig. 2-6: Virtual table and diagram containing the results after one frame (n FFTs)

As you can see many cells contain a value greater than '1'. A number greater than one expresses an overlap of several spectrums on this pixel. As the assumed frame consists of 10 spectrums, the sum of values in each column must equal '10'.

**Calculating percentages**

Now that all values have been transferred into the table, the R&S ESR converts the absolute numbers into relative values or percentages. The percentages are the basis of the final histogram that the R&S ESR shows on the display.

The percentage of one cell is simply the ratio of the number of hits in that cell over the number of accumulated spectrums.

**Example:**

The percentage of, e.g., the value in the highlighted cells would be 0.2 or 20% (2 hits and a total number of 10 spectrums,  $n=(2/10)*100%$ ). After the R&S ESR has calculated all percentages, the table would look like this:





For more information, see

- [chapter 2.3.3.1, "Using Persistence"](#), on page 26
- [chapter 2.3.3.2, "Activating Maxhold"](#), on page 27

### 2.3.1 Screen Layout of the Persistence Spectrum

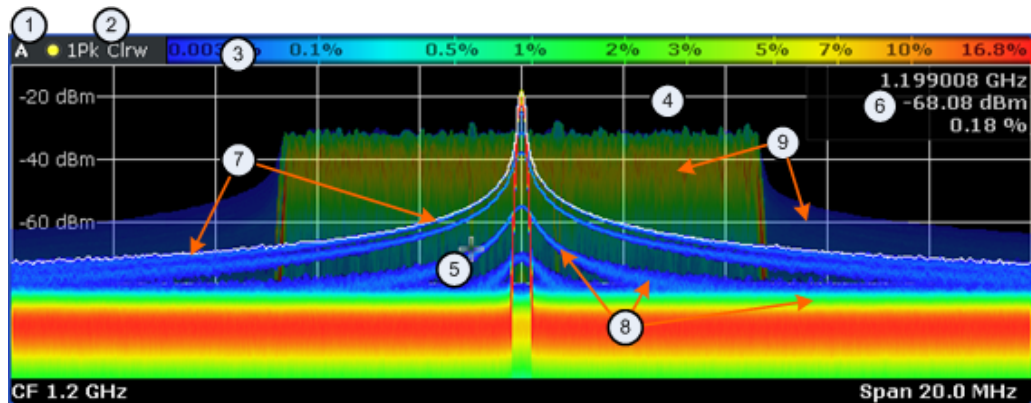

- 1 = Screen number
- 2 = Trace information for the realtime spectrum trace (trace mode and detector)
- 3 = Color map
- 4 = Trace window (or diagram area)
- 5 = Marker
- 6 = Marker information
- 7 = Realtime spectrum trace (white line)
- 8 = Persistence spectrum (colored trace)
- 9 = maxhold trace (weak color intensity)

The persistence spectrum has three 'layers':

- the realtime spectrum trace. This trace is always white so that you can recognize it inside the histogram. It is updated continuously.
- the histogram. The histogram is the main feature of the result display. The colors the histogram show the number of hits of level/frequency combinations. The number of FFTs each pixel in the measurement diagram contains depends on the granularity. The histogram is multicolored.
- the maxhold trace. The maxhold trace is a transparent trace in the background of the histogram that shows the maximum percentages that have been measured up to the present. The maxhold trace is in the 'background' of the result display with a lower intensity than the histogram. By default, the maxhold trace is inactive, i.e. it has an intensity of 0. You can, however, adjust the color intensity to the point where the maxhold trace has the same intensity as the regular histogram. The maxhold trace is also multicolored.

### 2.3.2 Applications of the Persistence Spectrum

The persistence spectrum is useful for any measurement task that requires information about the statistical frequency of a spectral event. When you know the relative frequency of an event, you can also deduce the probability with which that event will occur.

A typical application for the persistence spectrum is the detection of weak or hidden signals that occur infrequent. Weak signals may be hidden in the noise or occur in between strong pulses and therefore cannot be detected with standard result displays. The persistence spectrum on the other hand shows those signals because they have a different probability than other signals. With a different probability, the color mapping also is different and it is easy for you to identify those signals.

You can also identify spurs more easily with the persistence spectrum because their probability differs. With an active persistence, you can also see them or their shadows for a longer time on the result display which makes it easier not to miss them.

This fact also makes it easier to monitor the spectrum and, e.g. observe interfering signals in a frequency band reserved for a particular application. When monitoring the spectrum with the persistence spectrum, you can not only see interfering signals but also observe the frequency with which they occur and therefore derive from the density if it was a one time occurrence only or if the interfering signal is transmitted regularly.

There are however limits to the information the persistence spectrum is capable to provide. If you need to know, for example, how long a particular frequency/level combination is present, you have to use another result display, because the persistence spectrum doesn't tell whether there is a single very long pulse (e.g. one 5 ms pulse) or several short ones (e.g. ten 50 µs pulses).

### 2.3.3 Configuring the Persistence Spectrum

You can customize the persistence spectrum in several ways. You can change the colors with which the densities are visualized, you can change the persistence of the data and change the style of the displayed results.

[TRACe<n> \[ : DATA \]](#) on page 107

#### 2.3.3.1 Using Persistence

Persistence is a term to describe the time period shadows of past histogram traces remain visible in the display before fading away.

The term persistence has its origins in cathode ray tube devices (CRTs). It describes the time period one point on the display stays illuminated after it has been lit by the cathode ray. The higher the persistence, the longer you could observe the illuminated point on the display.

In the persistence spectrum, the persistence results from the moving 'density' (like a moving average) over a certain number of traces. The number of traces that are considered for calculating the density depend on the persistence length that you can define with the "Persistence" softkey. The longer the persistence, the more traces are part of the calculation and the deeper the history of displayed information gets. A spectral event that has occurred a single time is visible for up to 8 seconds. That means that colors will change as densities get smaller at coordinates with signal parts that are not constantly there, but still have the same intensity as the original signal. The rate of the color change is high with a low persistence and small with a high persistence.

Note that a signal with constant frequency and level characteristics does not show the effects of persistence on the trace. As soon as the power or frequency of a signal change slightly, however, the effect of persistence gets visible through color changes or changes in the shape of the trace.

You can turn off persistence if you set it to 0 seconds.

`DISPlay:WINDow<n>[:SUBWindow<m>]:TRACe<t>:PERSistence:DURation`  
on page 74

### Defining the granularity

The amount of data that the R&S ESR uses to draw a single frame in the persistence spectrum is variable. By default it uses the data that was captured in a 100 ms in the moving 'density'. With the "Persistence Granularity" softkey, you can set the amount of data that the R&S ESR uses to build the persistence spectrum by increasing or decreasing the persistence granularity.

`DISPlay:WINDow[:SUBWindow]:TRACe:PERSistence:GRANularity`  
on page 74

### 2.3.3.2 Activating Maxhold

The maxhold function remembers and shows the maximum densities that have been measured at each point in the diagram. The maxhold trace is visible as soon as you increase the color intensity and will remain visible until you reset the maxhold, turn it off or preset the R&S ESR.

#### Changing the color intensity

In its default state, the R&S ESR does not display the maxhold trace. You can turn it on by increasing the color intensity. With the "Maxhold Intensity" softkey, you can regulate the brightness of the trace up to the point where it is as intense as the current trace.

Note that the color intensity of the maxhold trace is lower than that of the trace itself. The color distribution, however, is the same for both traces.

`DISPlay:WINDow<n>[:SUBWindow<m>]:TRACe<t>:MAXHold[:INTensity]`  
on page 74

#### Resetting the maxhold trace

You can reset the maxhold trace with the "Maxhold Reset" softkey. The R&S ESR then starts to build the maxhold trace again.

`DISPlay:WINDow[:SUBWindow]:TRACe:MAXHold:RESet` on page 73

#### Turning off the maxhold trace

To turn off the maxhold trace, set the maxhold intensity to zero.

`DISPlay:WINDow<n>[:SUBWindow<m>]:TRACe<t>:MAXHold[:INTensity]`  
on page 74

### 2.3.3.3 Selecting the Style of the Trace

The R&S ESR offers two styles that you can apply to the persistence spectrum, vectorial or dotted display. Select the style of the trace with the "Style (Vec Dots)" softkey.

The vectorial display of the measurement results is an interpolation of all the individual points and therefore an interpolation of densities. The result is a persistence spectrum that contains no gaps between coordinates. Each point of the histogram is connected to the neighboring ones.

The dotted display on the other hand plots and colors only those coordinates where data has been actually measured. The result is a histogram made up out of literally thousands of individual points.

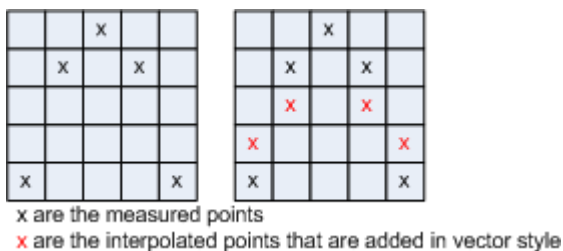

**Fig. 2-9: Dotted trace style vs Vector trace style**

`DISPlay:WINDow<n>[:SUBWindow<m>]:TRACe<t>:SYMBOL` on page 75

### 2.3.3.4 Customizing the Color Mapping

For more information, see [chapter 2.2.3.3, "Customizing the Color Mapping"](#), on page 16

## 3 Measurement Basics

- [Data Acquisition and Processing in a Realtime Analyzer](#).....29
- [Configuring Realtime Measurements](#).....31
- [Triggering Measurements](#).....34
- [Using Markers](#).....40
- [Detector Overview](#).....43
- [ASCII File Export Format](#).....43

### 3.1 Data Acquisition and Processing in a Realtime Analyzer

This chapter shows the way the R&S ESR acquires and processes the data compared to a conventional spectrum analyzer.

A conventional spectrum analyzer typically loses information after it has captured the signal ('blind time'). This is because the LO has to return to the start frequency after a sweep of the selected frequency range (LO flyback). Blind time therefore occurs after the data capture and signal processing and before the next data capture can begin.

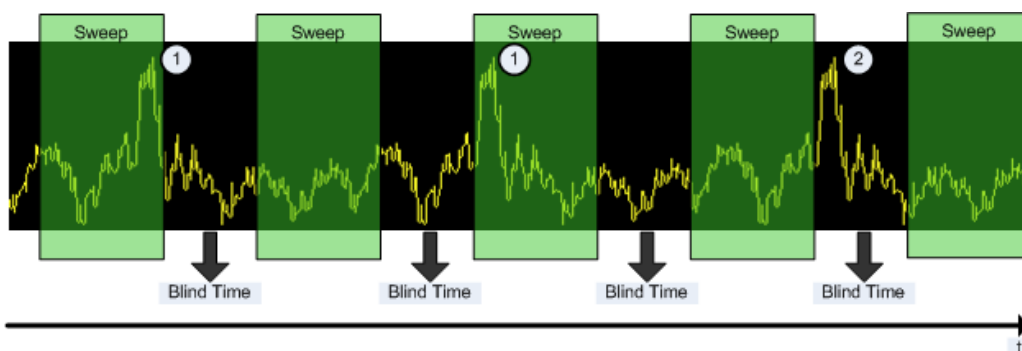

**Fig. 3-1: Conventional spectrum analyzer measurement principle**

= Note that the time axis is not true to scale. Blind time is a lot shorter in reality.

1 = Signals are captured by the sweep.

2 = Signal is missed by the sweep because of LO flyback (blind time).

Because of a number of reasons, a realtime analyzer does not lose any information.

First, there is no LO flyback because the LO of the realtime analyzer is set to a fixed frequency. Second, it performs overlapping Fast Fourier Transformations (FFT) instead of sweeping the spectrum or performing one FFT after another. The overlap of FFTs also ensures that the R&S ESR can process pulses with a length of at least one FFT with correct levels. Third, the R&S ESR captures data and performs FFTs at the same time instead of sequentially capturing data and performing FFT.

To get the results, the R&S ESR simultaneously performs several processing stages:

- Acquiring the data
- Processing the data

- Displaying the data

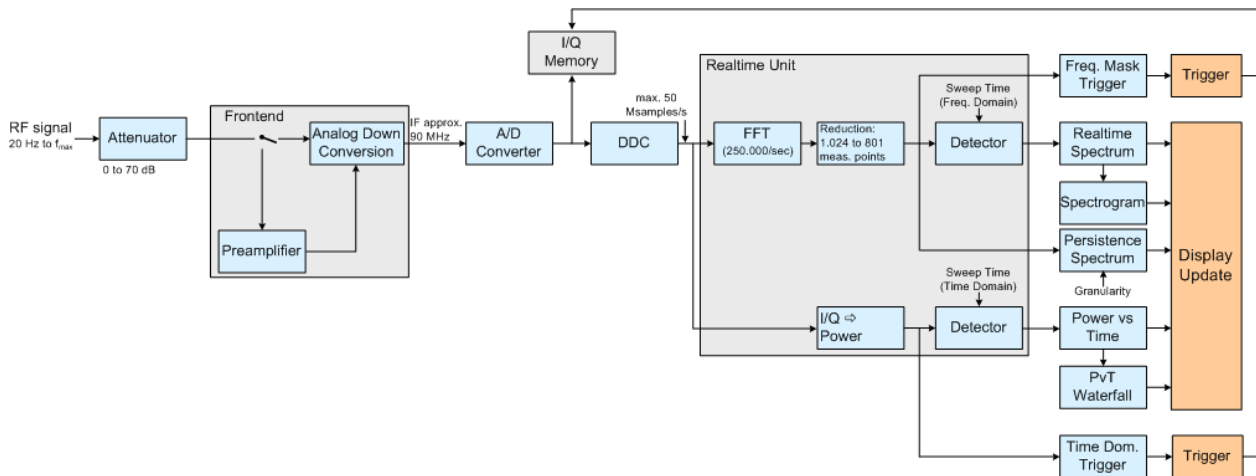

Fig. 3-2: Block diagram of the R&S ESR

### Acquiring the data

The data acquisition process is the same as in a conventional spectrum analyzer. First, the R&S ESR either attenuates the signal that you have applied to the RF input to get a signal level that the R&S ESR can handle or, if you have a weak signal, preamplifies the signal and then down-converts the RF signal to an intermediary frequency (IF), usually in several stages.

After the down-conversion, the R&S ESR samples the signal into a digital data stream that is the basis for the Fast Fourier Transformation (FFT). The sampling rate the R&S ESR uses for sampling is variable, but depends on the span you have set. The maximum span is 40 MHz.



Fig. 3-3: Continuous data stream

At the same time, the A/D data is captured in the I/Q memory.

### Processing the data

The R&S ESR then splits the data stream stored in the I/Q memory into data blocks whose length is 1024 samples each to prepare it for the FFT.

Then the R&S ESR performs the FFT on all data blocks it has acquired. The FFT processing rate of the R&S ESR is 250,000 FFTs per second.

The distinctive feature of a realtime analyzer is that it uses a particular amount of data more than once to get the measurement results. It takes the first data block of 1024 samples and performs the FFT on it. The second and all subsequent data blocks, however, do not start at the next sample (in the case of the second block, the 1025th), but at an earlier one. In fact, all data, except the first few samples, is processed more than once and overlapped to get the results.

At full span (40 MHz) this overlap of the FFTs is 80%. That means the second data block the R&S ESR performs the FFT on covers the last 80% of the data of the first FFT with only 20% new data. The third data block still covers 60% of the first data block and 80% of the second data block and so on.

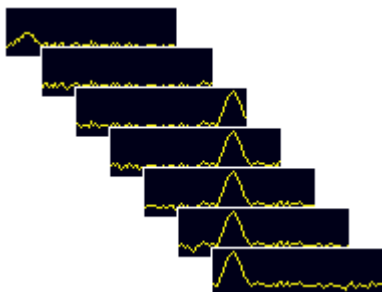

*Fig. 3-4: Overlapping FFTs*

The percentage of the overlap depends on the sampling rate and therefore on the span that you have set. With a span of 40 MHz, the overlap is 80%. If you reduce the span, the FFT machine tries to keep the FFT processing rate and increases the overlap accordingly. In that way, the overlap can increase up to a value of 1023 overlapping samples out of 1024 samples.

After the FFT is done and the spectrums have been calculated, the result is a stream of spectrums without information loss. For every spectrum, the R&S ESR gets 1024 measurement points. However, because of data reduction and the filter slope of the DDC, it only uses 801 points to get the displayed results.

#### **Displaying the data**

From here on, the data processing depends on the result display that you have selected. The details for every available result display are discussed below.

## **3.2 Configuring Realtime Measurements**

Three distinctive parameters for realtime analysis are the span, the sweep time and the resolution bandwidth.

The span and resolution bandwidth are directly coupled to each other.

### **3.2.1 Configuring the Sweep**

The R&S ESR provides various functions to configure the way it performs measurements.

In its default state, the R&S ESR continuously measures the signal that you have applied in the way described in [chapter 3.1, "Data Acquisition and Processing in a Realtime Analyzer"](#), on page 29 and according to the trigger settings.

You can interrupt the continuous measurement with the "Continuous Sweep Stop" softkey if you want to examine a signal further. To resume the continuous measurement, use the "Continuous Sweep Start" softkey.

In single sweep mode, on the other hand, the R&S ESR performs a finite number of sweeps. The number of sweeps that the R&S ESR performs depends on the sweep count, defined with the "Sweep Count" softkey in the sweep menu. If you set the sweep count to 0 or 1, the R&S ESR performs one sweep. One sweep corresponds to the sweep time. You can activate the single sweep mode with the "Single Sweep" softkey.

After the single sweep has ended, you can repeat the single sweep measurement with either the "Single Sweep" softkey or the "Continue Single Sweep" softkey. The difference is that when continuing the single sweep, the R&S ESR does not delete the trace data of the last measurement for averaging purposes. When you instead repeat the single sweep with the "Single Sweep" softkey, the R&S ESR completely rebuilds the trace from new data.

[INITiate<n>:CONTinuous](#) on page 93

[INITiate<n>:CONMeas](#) on page 92

[\[SENSe:\]SWEep:COUNT](#) on page 94

[CALCulate<n>:SGRam:FRAMe:COUNT](#) on page 78

### 3.2.2 Setting the Sweep Time

In the frequency domain of the realtime analyzer, the sweep time defines the number of FFTs that the R&S ESR combines in one frame or single sweep.

In realtime mode, the R&S ESR has a sweep time range from 52  $\mu$ s to 1 s, with 1 s processing 250.000 FFTs. The step size of the sweep time is 4  $\mu$ s.

The advantage of a small sweep time therefore is a very detailed evaluation and display of the signal that you are measuring. On the other hand, a high sweep time displays more time in a single frame. That means that you can observe a longer time span in the spectrogram the higher the sweep time is.

#### Manual setting of the sweep time

You can set the sweep time as you need with the "Sweeptime Manual". This softkey is available in the span, bandwidth and sweep menus.

[\[SENSe:\]SWEep:TIME](#) on page 94

#### Automatic setting of the sweep time

If you activate the automatic sweep time with the "Sweeptime Auto" softkey, the R&S ESR sets the sweep time to 30 ms. The "Sweeptime Auto" softkey is available in the bandwidth and sweep menus.

[\[SENSe:\]SWEep:TIME:AUTO](#) on page 94



### 3.2.3 Setting the Span

The span (or realtime bandwidth) defines the frequency range that the R&S ESR shows in result displays with a horizontal axis showing the frequency.

The span you should use depends on the signal that you are measuring. It should, however, be about twice as large as the bandwidth of the signal.

In realtime mode, the R&S ESR has a minimum span of 100 Hz and a maximum span of 40 MHz.

You can set the span in several ways.

#### Setting the span

You can set the directly with the "Span Manual" softkey or the SPAN key.

If you change the span in this way, the center frequency always corresponds to the center of the span and remains the same, no matter how you change the span.

[\[SENSe:\] FREQuency: SPAN](#) on page 84

#### Defining a start and stop frequency

Another way to set the span is to define a start and stop frequency with the "Start" and "Stop" softkeys in the frequency menu.

Changing the start and stop frequencies invalidates the center frequency and span settings that you have previously made.

Note that if you enter a start and stop frequency that would result in a span larger than 40 MHz, the R&S ESR always narrows the span down to 40 MHz.

#### Example:

If you first enter a start frequency of 100 MHz and then a stop frequency of 150 MHz, the R&S ESR adjusts the start frequency to 110 MHz.

If you first enter a stop frequency of 150 MHz and then a start frequency of 100 MHz, the R&S ESR adjusts the stop frequency to 140 MHz.

[\[SENSe:\] FREQuency: START](#) on page 85

[\[SENSe:\] FREQuency: STOP](#) on page 85

#### Restoring the full span

You can always restore the full span (40 MHz) with the "Full Span" softkey.

[\[SENSe:\] FREQuency: SPAN: FULL](#) on page 85

### 3.2.4 Setting the Resolution Bandwidth

The aspect of the signal as appears on the display of the R&S ESR depends on the resolution filter bandwidth that you have set. The resolution bandwidth determines the frequency resolution of a measurements.

The resolution bandwidth is directly coupled to the span of the R&S ESR. If you increase or decrease the span, the resolution bandwidth also goes up or down.

If necessary, you can apply a fix coupling ratio between the resolution bandwidth and the span in the "Coupling Ratio" menu. The R&S ESR provides several coupling ratios from which you can select.

A small resolution bandwidth has several advantages. The smaller the resolution bandwidth, the better you can observe signals whose frequencies are close together and the less noise is displayed. However, a small resolution bandwidth also leads to a slower measurement as it takes the filter more time to settle. That means that if you increase or decrease the resolution bandwidth, the R&S ESR adjusts the sweep time accordingly.

The R&S ESR has resolution bandwidths from 500 mHz to 200 kHz in 1-2-5 steps (1 Hz - 2 Hz - 5 Hz - 10 Hz etc.).

You can set the resolution bandwidth with the "Manual Res BW" softkey.

In addition, you can select several 6 dB resolution bandwidths. You can turn the functionality on with the "Res BW 6 dB (On Off)" softkey and then select the available bandwidths with the "Res BW Manual" softkey. For more information on these EMI bandwidths see the manual of the R&S ESR.

[SENSe:]BANDwidth|BWIDth[:RESolution] on page 85

[SENSe:]BANDwidth|BWIDth[:RESolution]:AUTO on page 86

## 3.3 Triggering Measurements

To respond to certain events and trigger a measurement when that event happens, the R&S ESR offers several trigger functions. You can access these via the TRIG key and the corresponding softkey menu.

This chapter describes trigger functions available for the measurements in realtime spectrum analyzer mode.

### 3.3.1 Working with the Frequency Mask Trigger

The Frequency Mask Trigger (FMT) is a trigger designed to trigger measurements if the signal violates certain conditions with respect to a frequency mask that you can define prior to the measurement.

To create and edit a frequency mask, you can access the corresponding dialog box via the "Frequency Mask" softkey in the trigger menu.

Opening the dialog box also opens a softkey submenu that contains various functionality to work with frequency masks.

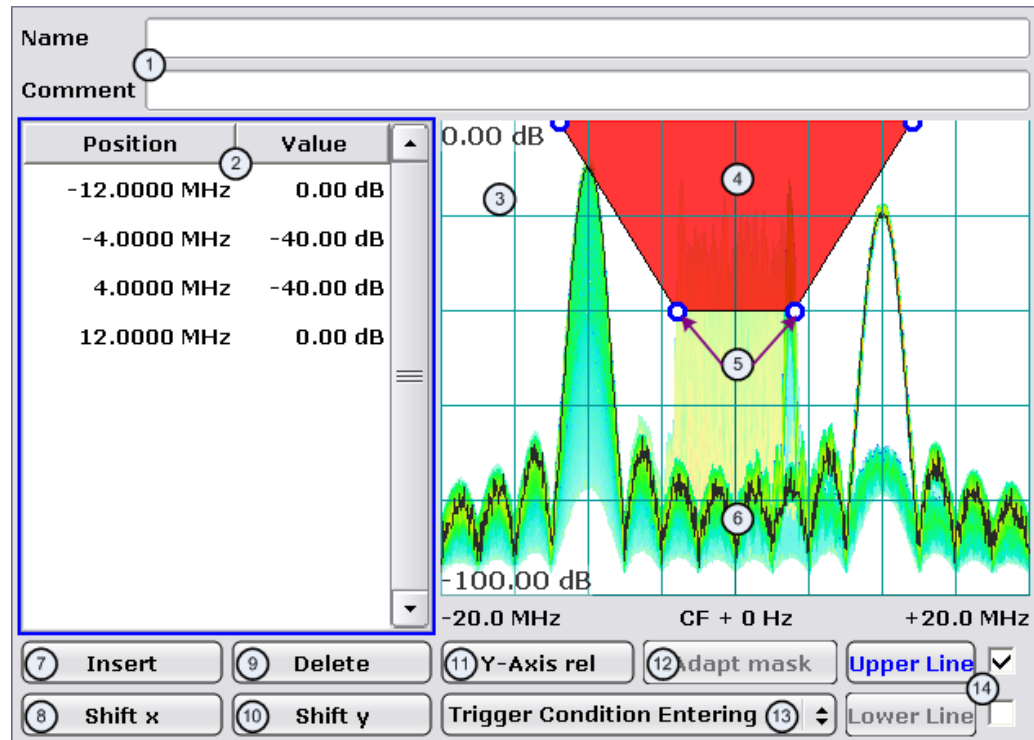

- 1 = Name and description of the frequency mask
- 2 = Mask point table: table containing all mask points
- 3 = Preview pane
- 4 = Frequency mask preview: the area the frequency mask currently covers is red
- 5 = Frequency mask data points: define the shape of the frequency mask
- 6 = Preview of the current measurement trace; type and shape depend on currently selected measurement
- 7 = Insert button: insert a new data points
- 8 = Shift X button: shifts the complete frequency mask horizontally
- 9 = Delete button: deletes an existing data points
- 10 = Shift Y button: shifts the complete frequency mask vertically
- 11 = Y-Axis Rel/Abs button: switches between relative (dB) and absolute (dBm) amplitude values
- 12 = Adapt Mask button: creates a frequency mask automatically
- 13 = Trigger Condition menu: sets the trigger condition
- 14 = Activate Line buttons: select the upper and lower frequency mask; check marks next to the buttons activate and deactivate a line

### 3.3.1.1 Creating a Frequency Mask

Upon opening the "Edit Frequency Mask" dialog box, the R&S ESR already provides a basic structure of an upper frequency mask in the live preview window.

It is also possible to create a new mask by pressing the "New Mask" softkey. The "New Mask" softkey resets the current shape of the mask to its default state.

#### Labelling a frequency mask

Assign a name to the frequency mask in the "Name" field. Activate the input in the "Name" field either by touching it or via the "Edit Name" softkey. This is also the save name of the frequency mask.

In addition to naming the mask, you can also comment on the frequency mask you are working on in the "Comment" field. Again, activate the input either by touching it or with the "Edit Comment" softkey.

Remote command:

[CALCulate<n>:MASK:COMMeNt](#) on page 99

[CALCulate<n>:MASK:NAME](#) on page 101

### Defining the frequency mask span

Define the span of the frequency mask.

The span defines the range that the frequency mask covers on the frequency axis.

Remote command:

[CALCulate<n>:MASK:SPAN](#) on page 101

### Working with upper and lower lines

A frequency mask may have an upper and a lower threshold, with the signal in between. The checkboxes next to the "Upper Line" and "Lower Line" buttons activate or deactivate the corresponding line. Note that it is not possible to deactivate both lines.

You can select the line you want to edit with the "Upper Line" / "Lower Line" buttons or by touching the corresponding area in the preview to apply any changes. The buttons turn blue if a line is selected and the R&S ESR shows the data points in the area covered by the mask in the preview pane.

Remote command:

[CALCulate<n>:MASK:LOWer\[:STATe\]](#) on page 100

[CALCulate<n>:MASK:UPPer\[:STATe\]](#) on page 102

### Setting the trigger condition

To make the trigger work, you need to set a trigger condition with the "Trigger Condition" button. The R&S ESR supports four conditions.

"Entering"	Activates the trigger as soon as the signal enters the frequency mask. To arm the trigger, the signal initially has to be outside the frequency mask.
"Leaving"	Activates the trigger as soon as the signal leaves the frequency mask. To arm the trigger, the signal initially has to be inside the frequency mask.
"Inside"	The trigger is active as long as the signal is inside the frequency mask. To arm the trigger, the signal initially has to be outside the frequency mask.
"Outside"	The trigger is active as long as the signal is outside the frequency mask. To arm the trigger, the signal initially has to be inside the frequency mask.

Remote command:

[TRIGger<n>\[:SEqueNce\]:MASK:CONDition](#) on page 103

### 3.3.1.2 Editing Mask Points

You can adjust the frequency mask any way you want by adding, removing and repositioning frequency mask data points.

Data points define the shape of the frequency mask. In the preview pane, the R&S ESR visualizes data points as blue circles. In addition, all data point positions are listed in the data point table. The number of data points is limited to 801.

Data points are defined by two values. The first value defines the position of the data point on the horizontal (frequency) axis. Frequency information is relative to the center frequency.

Note that in realtime mode, the span depends on the realtime bandwidth. That also means that the distance of a data point to the center frequency can never exceed 20 MHz as the maximum realtime bandwidth is 40 MHz.

The second value defines the position of the data point on the vertical (level) axis. By default, level information is relative to the reference level. You can, however, turn the level axis to absolute scaling with the "Y-Axis Abs/Rel" button. This also changes the unit of the vertical axis (dB for relative data points, dBm for absolute data points).

#### Adding data points

To add a new data point, press the "Insert" button or the "Insert Value Above" softkey. The R&S ESR always adds the data point to the left (or in case of the table, above) of the currently selected data point. The currently selected data point is highlighted gray in the table. If no data point was selected previously, the buttons add a new point next to the very first one.

#### Deleting data points

The "Delete" button or the "Delete Value" softkey remove a data point from the mask. The R&S ESR deletes the currently selected data point. If no data point is selected, it deletes the first one. The "Delete" button is inactive in that case.

#### Positioning data points

There are two ways to move a single data point.

In the preview pane, you can drag around the data points on the touchscreen or with a mouse and position it roughly in the place you want it to be. A more exact method is to edit the data point table itself and enter the frequencies and levels as you need.

Remote command:

`CALCulate<n>:MASK:LOWer[:DATA]` on page 100

`CALCulate<n>:MASK:UPPer[:DATA]` on page 102

### Shifting mask points as a whole

With the "Shift X" and "Shift Y" buttons you are able to move all mask points of a frequency mask as one. The "Shift X" button moves the mask point set horizontally, while the "Shift Y" button moves them vertically. This is an easy method to move mask points if the relative position of mask points to each other is alright already without adjusting each one by itself.

Remote command:

`CALCulate<n>:MASK:LOWer:SHIFt:X` on page 99

`CALCulate<n>:MASK:LOWer:SHIFt:Y` on page 100

`CALCulate<n>:MASK:UPPer:SHIFt:X` on page 101

`CALCulate<n>:MASK:UPPer:SHIFt:Y` on page 102

### Automatic alignment of the frequency mask

Instead of defining the position of every data point by hand, the R&S ESR is able to shape the frequency mask according to the shape of the current signal. On pressing the "Auto Set Mask" button, the R&S ESR forms the frequency mask around the current spectrum.

Note the the automatic alignment of the frequency mask works only for the upper frequency mask.

Remote command:

`CALCulate<n>:MASK:UPPer[:DATA]` on page 102

### 3.3.1.3 Managing Frequency Masks

To be able to reuse or edit a frequency mask that you have defined later, you can save and restore particular frequency mask configurations.

The R&S ESR stores files that contain such configurations on its internal hard disk.

#### Save Mask

The "Save" softkey opens a dialog box to save the current frequency mask configuration in a file.

If you do not name the file in the dialog box, the R&S ESR names the file like the name of the frequency mask itself.

#### Load Mask

The "Load" softkey opens a dialog box to restore a frequency mask.

The dialog box contains all frequency masks already on the hard disk of the R&S ESR. Select the mask you need and confirm the selection with the "Load" button.

Remote command:

Path selection:

`CALCulate<n>:MASK:CDIRectory` on page 99

Load mask:

`CALCulate<n>:MASK:NAME` on page 101

#### Delete Mask

The Delete softkey opens a dialog box to delete a previously saved frequency mask.

The "Delete" button deletes the file. Note that you have to confirm the deletion process.

Remote command:

`CALCulate<n>:MASK:DElete` on page 99

### 3.3.2 Using the Time Domain Trigger

The time domain trigger is a trigger designed to trigger measurements if the signal exceeds a particular power level. Activate and define a power level for the time domain trigger by pressing the "Time Domain Trigger" softkey in the trigger menu.

The time domain trigger is available for measurements in the time domain. You can turn it off by selecting the free run mode.

`TRIGger<n>[:SEquence]:TDTRigger:LEVel` on page 96

### 3.3.3 Using Other Triggers

Besides the frequency mask trigger and the time domain trigger, the R&S ESR features various other trigger modes.

Available trigger sources

- External  
Activate and define a power level for the external trigger by pressing the "Time Domain Trigger" softkey in the trigger menu.
- Free Run  
Turns off all trigger sources.

For more information see

- "Free Run" on page 58
- "External" on page 59

### 3.3.4 Using Pre- and Posttrigger

When using a trigger, you can set a "Pretrigger" and a "Posttrigger" period with the corresponding softkeys. Each can last up to three seconds. Both combined, however cannot be longer than four seconds.

**Example:**

If the pretrigger has a length of 3 seconds, the posttrigger can last a maximum of 1 second.

### 3.3.5 Rearming the Trigger and Stopping on Trigger

#### Auto Rearm

By default, a trigger event causes the R&S ESR to start a measurement and to immediately rearm the trigger. In that case, measurements are continuously triggered and measurement results may become obsolete in a very short time. The pre- and posttrigger periods are completely displayed.

#### Stop on Trigger

However, you may be interested in the results after the first trigger event only. To do so, you can activate the "Stop on Trigger" feature. If active, this feature does not rearm the trigger after the first trigger event has occurred and stop the measurement after one sweep. The measurement results will remain on the display. If a posttrigger is active, the R&S ESR includes this period in the result display. The pretrigger period may not be displayed.

You can return to the default state (continuous triggering) with the "Auto Rearm" softkey.

[TRIGger:MODE](#) on page 95

## 3.4 Using Markers

All of the result displays available in realtime spectrum mode support marker functionality.

Markers are a means to mark points of interest in the diagram, to read out measurement results or to quickly get hold of measurement results that are currently not visible. In most result displays, you can either use markers or deltamarkers with deltamarkers always having a relative position to a normal marker.

The marker that you can control is the active marker.

The R&S ESR displays all necessary information about the active marker inside the diagram area in the marker information field. The information that is displayed depends on the result display.

This chapter describes distinctive features of the marker functionality for the result displays in realtime spectrum mode.

For general information about markers and the contents of the marker, marker to and marker function softkey menus, see

- [chapter 5.2, "Using Markers"](#), on page 63

### 3.4.1 Markers in a Spectrogram

Upon pressing the MKR key, the R&S ESR opens an input field to define the position of the first marker.



**25.0 kHz** | **-1.998 s**

**Fig. 3-5: Marker input field**

Every marker in the spectrogram has two coordinates. If the realtime spectrum is active at the same time the spectrogram is active, the realtime spectrum markers also have two coordinates.

The first coordinate defines the frequency of the marker.

The second coordinate defines the position of the marker in time. The unit depends on whether the time stamp is active or not. If it is inactive, you have to define a particular frame number relative to the current frame. If not, you have to set the distance to the current frame in seconds. The R&S ESR then evaluates the corresponding frame number automatically. The time value for normal markers is always negative, because the temporal marker position is always relative to the current frame. Deltamarkers can also have positive values, if you set them on a frame recorded after the frame the marker is on.

The recording date and time of the frame (displayed in the spectrogram footer) is adjusted accordingly.

The available history depth defines the maximum time range.

As soon as the first marker is active, the R&S ESR also shows the marker information in the diagram area

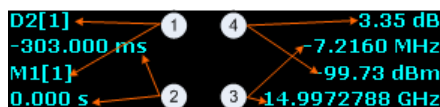

**Fig. 3-6: Marker information**

- 1 = Marker (Mx) and deltamarker (Dx) information including the trace number [x] the marker is on
- 2 = Position of the marker in time (relative to the marker in case of the deltamarker)
- 3 = Frequency position of the marker (relative to the marker in case of the deltamarker)
- 4 = Level of the marker position (relative to the marker in case of the deltamarker)

All results concerning normal markers are absolute values (frequency, level and time information) while results of the deltamarker are relative to the normal marker.

Markers and deltamarkers in the realtime spectrum result display are always coupled to the spectrogram and vice versa, no matter if you are viewing both at the same time or not.

In the realtime spectrum, markers have the form of a triangle (▼). As long as the spectrogram is running, markers are not available in the realtime spectrum. If you stop the spectrogram by switching to single sweep mode or by interrupting the continuous sweep mode, markers become available for the realtime spectrum. You can then select a particular frame in the spectrogram to recall the corresponding realtime spectrum, and place the markers there. The markers of spectrogram and realtime spectrum are always synchronized in time.

Markers in the spectrogram look like diamonds (◆). You can set them on any frame stored in the spectrogram history and on any frequency you want. No matter the sweep mode, they will be visible and stay where you have put them. If you place them too far in the past or too far from each other vertically or horizontally, however, it may be that one

or more markers are no longer visible in the result display. To see the marker in that case, you have to select it first.

For more information, see

- [chapter 2.2.3.1, "Working with the Spectrogram History"](#), on page 12

### Setting a marker on a trigger event

In the spectrogram, you can set the marker directly on the most recent trigger event with the "Marker to Trigger" softkey available in the marker to menu. The functionality is available only if there was a trigger event already.

For a list of remote commands to control markers and deltamarkers see

- [chapter 6.4.2.3, "Positioning Markers in the Spectrogram"](#), on page 121
- [chapter 6.4.2.5, "Positioning Delta Markers in the Spectrogram"](#), on page 130

## 3.4.2 Markers in the Persistence Spectrum

If you press the MKR key in the persistence spectrum, the R&S ESR activates a marker and opens a dialog box to define the position of the marker. In the persistence spectrum the marker looks like cross hairs with the center focusing on the pixel that you want to analyze.

A Marker in the persistence spectrum has two coordinates. The first coordinate defines the frequency position of the marker. The second coordinate defines the position on the amplitude axis.

In addition to those two values, the marker provides the number of times the pixel it is on has been hit by the signal. The result is the statistical frequency in %.

As soon as the first marker is active, the R&S ESR also shows the marker information in the diagram area.

All results concerning normal markers are absolute values (frequency and level) while results of the frequency and amplitude information of a deltamarker are relative to the normal marker. The statistical frequency distribution that the marker also shows is always absolute.

### Defining the trace to put the marker on

In the persistence spectrum result display, you can place each marker either on the persistence trace or the maxhold trace, if it is active. The R&S ESR then returns the data of the marker position for the corresponding trace. You can select the trace with the "(Current Maxhold)" softkey.

`CALCulate<n>:MARKer<m>:TRACe` on page 109

### 3.5 Detector Overview

The measurement detector for the individual display modes can be selected directly by the user or set automatically by the R&S ESR. The detector activated for the specific trace is indicated in the corresponding trace display field by an abbreviation.

For more information on available detectors see the documentation of the base unit.

All detectors work in parallel in the background, which means that the measurement speed is independent of the detector combination used for different traces.



#### Number of measured values

During a frequency sweep, the R&S ESR increments the first local oscillator in steps that are smaller than approximately 1/10 of the bandwidth. This ensures that the oscillator step speed is conform to the hardware settling times and does not affect the precision of the measured power.

The number of measured values taken during a sweep is independent of the number of oscillator steps. It is always selected as a multiple or a fraction of 691 (= default number of trace points displayed on the screen). Choosing less than 691 measured values (e.g. 125 or 251) will lead to an interpolated measurement curve, choosing more than 691 points (e.g. 1001, 2001 ...) will result in several measured values being overlaid at the same frequency position.



#### RMS detector and VBW

If the RMS detector is selected, the video bandwidth in the hardware is bypassed. Thus, duplicate trace averaging with small VBWs and RMS detector no longer occurs. However, the VBW is still considered when calculating the sweep time. This leads to a longer sweep time for small VBW values. Thus, you can reduce the VBW value to achieve more stable trace curves even when using an RMS detector. Normally, if the RMS detector is used the sweep time should be increased to get more stable trace curves.

### 3.6 ASCII File Export Format

The data of the file header consist of three columns, each separated by a semicolon: parameter name; numeric value; basic unit. The data section starts with the keyword "Trace <n>" (<n> = number of stored trace), followed by the measured data in one or several columns (depending on measurement) which are also separated by a semicolon.

File contents: header and data section	Description
Date;01.Apr 2010;	Date of data set storage
Screen;A;	Instrument mode
Points per Symbol;4;	Points per symbol

File contents: header and data section	Description
x Axis Start;-13;sym;	Start value of the x axis
x Axis Stop;135;sym;	Stop value of the x axis
Ref value y axis;-10.00;dBm;	Y axis reference value
Ref value position;100;%;	Y axis reference position
Trace;1;	Trace number
Meas;Result;	Result type
Meas Signal;Magnitude;	Result display
Demodulator;Offset QPSK;	Demodulation type
ResultMode;Trace;	Result mode
x unit;sym;	Unit of the x axis
y unit;dBm;	Unit of the y axis
Trace Mode;Clear Write;	Trace mode
Values;592;	Number of results
<values>	List of results

## 4 Configuration

Realtime measurements require a special operating mode on the R&S ESR, which you activate using the MODE key on the front panel.

When you activate a measurement channel in realtime mode, a measurement for the input signal is started automatically with the default configuration. The "Measurement" menu is displayed and provides access to the most important configuration functions.

The application provides two main ways to configure a measurement: softkey menus and dialog boxes.

Softkey menus are located on the right side of the display. They open when you press one of the keys on the R&S ESR front panel or as a submenu when you press one of the softkeys.

Dialog boxes usually open when you press a particular softkey.

Note that for easy access, some functions may be available in more than one softkey menu or dialog box.

### 4.1 Result Display Selection

For more information on the result displays available for realtime measurements see [chapter 2, "Measurements and Result Displays"](#), on page 7.

#### **Persistence Spectrum**

Starts the Persistence Spectrum result display.

#### **Real-Time Spectrum**

Starts the Realtime Spectrum result display.

#### **Spectrogram**

Starts the Spectrogram result display.

#### **Display Config**

Opens a dialog box to configure the screen layout.

For more information see [chapter 2, "Measurements and Result Displays"](#), on page 7.

Remote command:

`CALCulate<n>:FEED` on page 72

#### **Replay Zoom (On Off)**

Turns the spectrogram zoom on and off.

For more information see [chapter 2.2.3.2, "Zooming into the Spectrogram"](#), on page 14.

Remote command:

Turn zoom on and off:

`DISPlay:WINDow[:SUBWindow]:ZOOM:STATe` on page 73

Define the zoom area:

`DISPlay:WINDow[:SUBWindow]:ZOOM:AREA` on page 72

## 4.2 Result Display Configuration

Each result display available with the realtime application features some settings that have an effect on that result display only. The following paragraphs give a short overview of the functions available for the result displays of the realtime application.

For a more comprehensive description see [chapter 2.2.3, "Configuring the Spectrogram"](#), on page 12 and [chapter 2.3.3, "Configuring the Persistence Spectrum"](#), on page 26.

- [Persistence Spectrum](#).....46
- [Spectrogram](#).....47

### 4.2.1 Persistence Spectrum

<a href="#">Color Mapping</a> .....	46
<a href="#">Persistence</a> .....	46
<a href="#">Maxhold Intensity</a> .....	47
<a href="#">Maxhold Reset</a> .....	47
<a href="#">Style</a> .....	47

#### Color Mapping

Opens a dialog box to configure the persistence spectrum color map.

For more information see [chapter 2.2.3.3, "Customizing the Color Mapping"](#), on page 16.

Remote command:

See [chapter 6.2.2.2, "Working with the Color Map"](#), on page 75.

#### Persistence

Defines the persistence of the displayed data.

For more information see [chapter 2.3.3.1, "Using Persistence"](#), on page 26.

Remote command:

Turn persistence on and off:

`DISPlay:WINDow<n>[:SUBWindow<m>]:TRACe<t>:PERSistence[:STATe]`  
on page 75

Defin the persistence:

`DISPlay:WINDow<n>[:SUBWindow<m>]:TRACe<t>:PERSistence:DURation`  
on page 74

**Maxhold Intensity**

Defines the intensity of the maxhold trace.

For more information see [chapter 2.3.3.2, "Activating Maxhold"](#), on page 27.

Remote command:

Turn the maxhold trace on and off:

`DISPlay:WINDow<n>[:SUBWindow<m>]:TRACe:MAXHold[:STATe]`  
on page 74

Define the intensity of the maxhold trace.

`DISPlay:WINDow<n>[:SUBWindow<m>]:TRACe<t>:MAXHold[:INTensity]`  
on page 74

**Maxhold Reset**

Resets the maxhold trace.

For more information see [chapter 2.3.3.2, "Activating Maxhold"](#), on page 27.

Remote command:

`DISPlay:WINDow[:SUBWindow]:TRACe:MAXHold:RESet` on page 73

**Style**

Selects the way the persistence spectrum data is displayed.

For more information see [chapter 2.3.3.3, "Selecting the Style of the Trace"](#), on page 28.

Remote command:

`DISPlay:WINDow<n>[:SUBWindow<m>]:TRACe<t>:SYMBol` on page 75

## 4.2.2 Spectrogram

**Color Mapping**

Opens a dialog box to configure the spectrogram color map.

For more information see [chapter 2.2.3.3, "Customizing the Color Mapping"](#), on page 16.

Remote command:

See [chapter 6.2.3.2, "Working with the Color Map"](#), on page 81.

**History Depth**

Defines the number of spectrogram frames that the R&S ESR saves.

For more information see ["Defining the History Depth"](#) on page 12.

Remote command:

`CALCulate<n>:SGRam:HDEPth` on page 79

**Frame Count**

Defines the number of frames contained in a single sweep.

For more information see "Defining a Frame Count" on page 12.

Remote command:

`CALCulate<n>:SGRam:FRAMe:COUNT` on page 78

#### Clear Spectrogram

Deletes the contents of the spectrogram.

For more information see "Clearing the Spectrogram" on page 13.

Remote command:

`CALCulate<n>:SGRam:CLEAr[:IMMediate]` on page 77

#### Time Stamp (On Off)

Turns the display of the time information for a particular frame on and off.

For more information see "Using the Time Stamp" on page 13.

Remote command:

`CALCulate<n>:SGRam:TSTamp[:STATe]` on page 80

## 4.3 Common Measurement Settings

Common measurement settings are settings that have an effect on the measurement, regardless of the result display you are currently using (except where noted).

- [Configuring the Sweep](#).....48
- [Defining the Horizontal Diagram Axis](#).....50
- [Defining Level Characteristics](#).....52
- [Selecting the Measurement Bandwidth](#).....57
- [Triggering Measurements](#).....58

### 4.3.1 Configuring the Sweep

The "Sweep" menu contains all functionality to define characteristics of the measurement process.

- ▶ To access the "Sweep" menu, press the SWEEP key on the R&S ESR front panel.

<a href="#">Continuous Sweep Stop / Start</a> .....	49
<a href="#">Single Sweep</a> .....	49
<a href="#">Continue Single Sweep</a> .....	49
<a href="#">Select Frame</a> .....	49
<a href="#">Sweptime Manual (F) / (T) / Auto</a> .....	49
<a href="#">Sweep Count</a> .....	49
<a href="#">Continue Frame (On Off)</a> .....	50
<a href="#">Frame Count</a> .....	50
<a href="#">Clear Spectrogram</a> .....	50



**Continuous Sweep Stop / Start**

Interrupts, starts or resumes a continuous sweep.

For more information see [chapter 3.2.1, "Configuring the Sweep"](#), on page 31.

Remote command:

`INITiate<n>:CONTinuous` on page 93

**Single Sweep**

Initiates a single sweep.

For more information see [chapter 3.2.1, "Configuring the Sweep"](#), on page 31.

Remote command:

`INITiate<n>[:IMMediate]` on page 93

**Continue Single Sweep**

Initiates a single sweep that includes the data of previous measurements in the trace averaging process.

For more information see [chapter 3.2.1, "Configuring the Sweep"](#), on page 31.

Persistence spectrum only.

Remote command:

`INITiate<n>:CONMeas` on page 92

**Select Frame**

Selects a particular frame number of the spectrogram.

For more information see [chapter 2.2.3.1, "Working with the Spectrogram History"](#), on page 12.

Spectrogram measurements only.

Remote command:

`CALCulate<n>:SGRam:FRAMe:SElect` on page 78

**Sweeptime Manual (F) / (T) / Auto**

Defines the sweep time for measurements in the frequency domain "(F)" or time domain "(T)".

You can define the sweep time manually or automatically.

For more information see [chapter 3.2.2, "Setting the Sweep Time"](#), on page 32.

Remote command:

Manual sweeptime:

`[SENSe:] SWEEp:TIME` on page 94

Automatic sweeptime:

`[SENSe:] SWEEp:TIME:AUTO` on page 94

**Sweep Count**

Defines the number of sweeps performed during a single sweep sequence.

For more information see [chapter 3.2.1, "Configuring the Sweep"](#), on page 31.

Remote command:

`[SENSe:] SWEEp:COUNT` on page 94

**Continue Frame (On Off)**

Turns automatic clearing of the spectrogram contents after each sweep on and off.

For more information see [chapter 2.2.3.1, "Working with the Spectrogram History"](#), on page 12.

Spectrogram measurements only.

Remote command:

`CALCulate<n>:SGRam:CONT` on page 77

**Frame Count**

Defines the number of traces the R&S ESR plots in the spectrogram result display in a single sweep.

For more information see [chapter 2.2.3.1, "Working with the Spectrogram History"](#), on page 12.

Spectrogram measurements only.

Remote command:

`CALCulate<n>:SGRam:FRAMe:COUNT` on page 78

**Clear Spectrogram**

Clears the contents of the spectrogram.

For more information see [chapter 2.2.3.1, "Working with the Spectrogram History"](#), on page 12.

Spectrogram measurements only.

Remote command:

`CALCulate<n>:SGRam:CLEAr[:IMMediate]` on page 77

**4.3.2 Defining the Horizontal Diagram Axis**

The "Span" and "Frequency" menus contain all functions necessary to configure the horizontal axis.

- ▶ To access the "Frequency" menu, press the **FREQ** key on the R&S ESR front panel.
- ▶ To access the "Span" menu, press the **SPAN** key on the R&S ESR front panel.

Center.....	50
Center Frequency Stepsize.....	51
Start / Stop.....	51
Frequency Offset.....	51
Span Manual.....	51
Sweptime Manual (F) / (T).....	52
Full Span.....	52

**Center**

Defines the center or measurement frequency.

The available frequency range depends on the instrument model. For more information see the data sheet.

Remote command:

[\[SENSe:\] FREQuency:CENTer](#) on page 83

### Center Frequency Stepsize

Defines the step size by which the center frequency is increased or decreased when the arrow keys are pressed. When you use the rotary knob the center frequency changes in steps of only 1/10 of the "Center Frequency Stepsize".

"0.1*Span"	The stepsize is 10 % of the current span.
"0.5*Span"	The stepsize is 50 % of the current span.
"x*Span"	The stepsize is a percentage of the current span that you can define manually.
"= Center"	The stepsize is matched to the current center frequency.
"= Marker"	The stepsize is matched to the current marker frequency. Available only if a marker is active.
"Manual"	The stepsize is a fixed frequency that you define manually.

Remote command:

Stepsize coupling:

[\[SENSe:\] FREQuency:CENTer:STEP:LINK](#) on page 84

Manual stepsize as a function of the span:

[\[SENSe:\] FREQuency:CENTer:STEP:LINK:FACTor](#) on page 84

Manual stepsize in Hz:

[\[SENSe:\] FREQuency:CENTer:STEP](#) on page 83

### Start / Stop

Defines the start and stop frequency.

For more information see [chapter 3.2.3, "Setting the Span"](#), on page 33.

Remote command:

Start frequency:

[\[SENSe:\] FREQuency:START](#) on page 85

Stop frequency:

[\[SENSe:\] FREQuency:STOP](#) on page 85

### Frequency Offset

Defines a frequency offset in the range from -100 GHz to 100 GHz.

The offset shifts the displayed frequency range along the x-axis by a certain amount.

Remote command:

[\[SENSe:\] FREQuency:OFFSet](#) on page 84

### Span Manual

Defines the frequency span.

The frequency span has a range from 100 Hz to 40 MHz. If you set a span of 0 Hz, the R&S ESR enters the time domain.

Remote command:

[SENSe:] FREQuency: SPAN on page 84

#### Sweeptime Manual (F) / (T)

Defines the sweep time for measurements in the frequency domain "(F)" or time domain "(T)".

For more information see [chapter 3.2.2, "Setting the Sweep Time"](#), on page 32.

Remote command:

[SENSe:] SWEep: TIME on page 94

#### Full Span

Restore the full span of 40 MHz.

Remote command:

[SENSe:] FREQuency: SPAN: FULL on page 85

### 4.3.3 Defining Level Characteristics

The Amplitude menu contains all functions necessary to define level characteristics and to configure the vertical diagram axis.

For more comprehensive information on selected topics see the operating manual of the R&S ESR.

► To access the "Amplitude" menu, press the AMPT key on the R&S ESR front panel.

Ref Level.....	53
Range.....	53
L Range Log 100 dB.....	53
L Range Log 50 dB.....	53
L Range Log 10 dB.....	54
L Range Log 5 dB.....	54
L Range Log 1 dB.....	54
L Range Log Manual.....	54
L Range Linear %.....	54
L Range Lin. Unit.....	55
Unit.....	55
Preamp On/Off.....	55
RF Atten Manual/Mech Att Manual.....	55
RF Atten Auto/Mech Att Auto.....	56
Ref Level Offset.....	56
Ref Level Position.....	56
Grid Abs/Rel .....	56
Noise Correction.....	56
Input (AC/DC).....	57
Input 50 Ω/75 Ω .....	57

**Ref Level**

Opens an edit dialog box to enter the reference level in the current unit (dBm, dBμV, etc).

The reference level is the maximum value the AD converter can handle without distortion of the measured value. Signal levels above this value will not be measured correctly, which is indicated by the "IFOVL" status display.

Remote command:

`DISPlay[:WINDow<n>]:TRACe<t>:Y[:SCALe]:RLEVel` on page 88

**Range**

Opens a submenu to define the display range of the level axis.

- [Range Log 100 dB](#)
- [Range Log 50 dB](#)
- [Range Log 10 dB](#)
- [Range Log 5 dB](#)
- [Range Log 1 dB](#)
- [Range Log Manual](#)
- [Range Linear %](#)
- [Range Lin. Unit](#)

**Range Log 100 dB ← Range**

Sets the level display range to 100 dB.

Remote command:

Logarithmic scaling:

`DISP:WIND:TRAC:Y:SPAC LOG`, see `DISPlay[:WINDow<n>]:TRACe<t>:Y:SPACing` on page 88

Display range:

`DISP:WIND:TRAC:Y 100DB`, see `DISPlay[:WINDow<n>]:TRACe<t>:Y[:SCALe]` on page 87

**Range Log 50 dB ← Range**

Sets the level display range to 50 dB.

Remote command:

Logarithmic scaling:

`DISP:WIND:TRAC:Y:SPAC LOG`, see `DISPlay[:WINDow<n>]:TRACe<t>:Y:SPACing` on page 88

Display range:

`DISP:WIND:TRAC:Y 50DB`, see `DISPlay[:WINDow<n>]:TRACe<t>:Y[:SCALe]` on page 87

**Range Log 10 dB ← Range**

Sets the level display range to 10 dB.

Remote command:

Logarithmic scaling:

DISP:WIND:TRAC:Y:SPAC LOG, see [DISPlay\[:WINDow<n>\]:TRACe<t>:Y:SPACing](#) on page 88

Display range:

DISP:WIND:TRAC:Y 10DB, see [DISPlay\[:WINDow<n>\]:TRACe<t>:Y\[:SCALE\]](#) on page 87

**Range Log 5 dB ← Range**

Sets the level display range to 5 dB.

Remote command:

Logarithmic scaling:

DISP:WIND:TRAC:Y:SPAC LOG, see [DISPlay\[:WINDow<n>\]:TRACe<t>:Y:SPACing](#) on page 88

Display range:

DISP:WIND:TRAC:Y 5DB, see [DISPlay\[:WINDow<n>\]:TRACe<t>:Y\[:SCALE\]](#) on page 87

**Range Log 1 dB ← Range**

Sets the level display range to 1 dB.

Remote command:

Logarithmic scaling:

DISP:WIND:TRAC:Y:SPAC LOG, see [DISPlay\[:WINDow<n>\]:TRACe<t>:Y:SPACing](#) on page 88

Display range:

DISP:WIND:TRAC:Y 1DB, see [DISPlay\[:WINDow<n>\]:TRACe<t>:Y\[:SCALE\]](#) on page 87

**Range Log Manual ← Range**

Opens an edit dialog box to define the display range of a logarithmic level axis manually.

Remote command:

Logarithmic scaling:

DISP:WIND:TRAC:Y:SPAC LOG, see [DISPlay\[:WINDow<n>\]:TRACe<t>:Y:SPACing](#) on page 88

Display range:

[DISPlay\[:WINDow<n>\]:TRACe<t>:Y\[:SCALE\]](#) on page 87

**Range Linear % ← Range**

Selects linear scaling for the level axis in %.

The grid is divided into decadal sections.

Markers are displayed in the selected unit ("Unit" softkey). Delta markers are displayed in % referenced to the voltage value at the position of marker 1. This is the default setting for linear scaling.

Remote command:

DISP:TRAC:Y:SPAC LIN, see [DISPlay\[:WINDow<n>\]:TRACe<t>:Y:SPACing](#) on page 88

#### Range Lin. Unit ← Range

Selects linear scaling in dB for the level display range, i.e. the horizontal lines are labeled in dB.

Markers are displayed in the selected unit ("Unit" softkey). Delta markers are displayed in dB referenced to the power value at the position of marker 1.

Remote command:

DISP:TRAC:Y:SPAC LDB, see [DISPlay\[:WINDow<n>\]:TRACe<t>:Y:SPACing](#) on page 88

#### Unit

Opens the "Unit" submenu to select the unit for the level axis.

The default setting in spectrum mode is dBm.

If a transducer is switched on, the softkey is not available.

In general, the signal analyzer measures the signal voltage at the RF input. The level display is calibrated in RMS values of an unmodulated sine wave signal. In the default state, the level is displayed at a power of 1 mW (= dBm). Via the known input impedance (50 Ω or 75 Ω), conversion to other units is possible. The following units are available and directly convertible:

- dBm
- dBmV
- dBμV
- dBμA
- dBpW
- Volt
- Ampere
- Watt

Remote command:

[CALCulate<n>:UNIT:POWer](#) on page 86

#### Preamp On/Off

Switches the preamplifier on and off.

Remote command:

[INPut:GAIN:STATe](#) on page 89

#### RF Atten Manual/Mech Att Manual

Opens an edit dialog box to enter the attenuation, irrespective of the reference level. If electronic attenuation is activated (option R&S FSV-B25 only; "EI Atten Mode Auto" softkey), this setting defines the mechanical attenuation.

The mechanical attenuation can be set in 10 dB steps.

The RF attenuation can be set in 5 dB steps (with option R&S FSV-B25: 1 dB steps). The range is specified in the data sheet. If the current reference level cannot be set for the set RF attenuation, the reference level is adjusted accordingly.

The RF attenuation defines the level at the input mixer according to the formula:

$$\text{level}_{\text{mixer}} = \text{level}_{\text{input}} - \text{RF attenuation}$$

**Note:** The maximum mixer level allowed is **0 dBm**. Mixer levels above this value may lead to incorrect measurement results, which are indicated by the "OVLd" status display. The increased mixer level allows for an improved signal, but also increases the risk of overloading the instrument!

Remote command:

`INPut:ATTenuation` on page 89

### RF Atten Auto/Mech Att Auto

Sets the RF attenuation automatically as a function of the selected reference level. This ensures that the optimum RF attenuation is always used. It is the default setting.

Remote command:

`INPut:ATTenuation:AUTO` on page 89

### Ref Level Offset

Opens an edit dialog box to enter the arithmetic level offset. This offset is added to the measured level irrespective of the selected unit. The scaling of the y-axis is changed accordingly. The setting range is  $\pm 200$  dB in 0.1 dB steps.

Remote command:

`DISPlay[:WINDow<n>]:TRACe<t>:Y[:SCALe]:RLEVel:OFFSet` on page 88

### Ref Level Position

Opens an edit dialog box to enter the reference level position, i.e. the position of the maximum AD converter value on the level axis. The setting range is from -200 to +200 %, 0 % corresponding to the lower and 100 % to the upper limit of the diagram.

### Grid Abs/Rel

Switches between absolute and relative scaling of the level axis (not available with "Linear" range).

- |       |   |
|-------|---|
| "Abs" | Absolute scaling: The labeling of the level lines refers to the absolute value of the reference level. Absolute scaling is the default setting.   |
| "Rel" | Relative scaling: The upper line of the grid is always at 0 dB. The scaling is in dB whereas the reference level is always in the set unit (for details on unit settings see the "Unit" softkey). |

Remote command:

`DISPlay[:WINDow<n>]:TRACe<t>:Y[:SCALe]:MODE` on page 87

### Noise Correction

If activated, the results are corrected by the instrument's inherent noise, which increases the dynamic range.



"ON"	A reference measurement of the instrument's inherent noise is carried out. The noise power measured is then subtracted from the power in the channel that is being examined. The inherent noise of the instrument depends on the selected center frequency, resolution bandwidth and level setting. Therefore, the correction function is disabled whenever one of these parameters is changed. A disable message is displayed on the screen. Noise correction must be switched on again manually after the change.
"OFF"	No noise correction is performed.
"AUTO"	Noise correction is performed. After a parameter change, noise correction is restarted automatically and a new correction measurement is performed.

Remote command:

[\[SENSe:\]POWer:NCORrection](#) on page 90

#### Input (AC/DC)

Toggles the RF input of the R&S ESR between AC and DC coupling.

Remote command:

[INPut:COUPling](#) on page 89

#### Input 50 Ω/75 Ω

Uses 50 Ω or 75 Ω as reference impedance for the measured levels. Default setting is 50 Ω.

The setting 75 Ω should be selected if the 50 Ω input impedance is transformed to a higher impedance using a 75 Ω adapter of the RAZ type (= 25 Ω in series to the input impedance of the instrument). The correction value in this case is 1.76 dB = 10 log (75 Ω/50 Ω).

All levels specified in this Operating Manual refer to the default setting of the instrument (50 Ω).

Remote command:

[INPut:IMPedance](#) on page 90

### 4.3.4 Selecting the Measurement Bandwidth

The "Bandwidth" menu contains all functions necessary to configure the measurement bandwidth.

- ▶ To access the "Bandwidth" menu, press the BW key on the R&S ESR front panel.

<a href="#">Res BW Manual</a> .....	57
<a href="#">Sweptime Manual (F) / (T) / Auto</a> .....	58
<a href="#">Coupling Ratio</a> .....	58

#### Res BW Manual

Defines the resolution bandwidth.

For more information see [chapter 3.2, "Configuring Realtime Measurements"](#), on page 31.

Remote command:

`[SENSe:]BANDwidth|BWIDth[:RESolution]` on page 85

`[SENSe:]BANDwidth|BWIDth[:RESolution]:AUTO` on page 86

#### **Sweptime Manual (F) / (T) / Auto**

Defines the sweep time for measurements in the frequency domain "(F)" or time domain "(T)".

You can define the sweep time manually or automatically.

For more information see [chapter 3.2.2, "Setting the Sweep Time"](#), on page 32.

Remote command:

`[SENSe:]SWEep:TIME` on page 94

`[SENSe:]SWEep:TIME:AUTO` on page 94

#### **Coupling Ratio**

Opens a submenu to define a fix coupling ratio between resolution bandwidth and span.

The following coupling ratios are available.

- Span / RBW 3333
- Span / RBW 1666
- Span / RBW 833
- Span / RBW 416
- Span / RBW 208

Remote command:

`[SENSe:]BANDwidth|BWIDth[:RESolution]:RATio` on page 86

### **4.3.5 Triggering Measurements**

- ▶ To access the "Trigger" menu, press the TRIG key on the R&S ESR front panel.

Free Run.....	58
External.....	59
Frequency Mask.....	59
Time Domain.....	59
Pretrigger / Posttrigger.....	59
Auto Rearm.....	59
Stop On Trigger.....	59

#### **Free Run**

The start of a sweep is not triggered. Once a measurement is completed, another is started immediately.

Remote command:

`TRIG:SOUR IMM`, see `TRIGger<n>[:SEQUence]:SOURce` on page 96

**External**

Defines triggering via a TTL signal at the "EXT TRIG/GATE IN" input connector on the rear panel.

Remote command:

TRIG:SOUR EXT, see [TRIGger<n>\[:SEQuence\]:SOURce](#) on page 96

**Frequency Mask**

Opens a submenu to configure the frequency mask trigger.

For more information see [chapter 3.3.1, "Working with the Frequency Mask Trigger"](#), on page 34.

Remote command:

see [chapter 6.3.5.2, "Using the Frequency Mask Trigger"](#), on page 97

**Time Domain**

Selects the time domain trigger.

For more information see [chapter 3.3.2, "Using the Time Domain Trigger"](#), on page 39.

Remote command:

[TRIGger<n>\[:SEQuence\]:TDTRigger:LEVel](#) on page 96

**Pretrigger / Posttrigger**

Defines a pre- and posttrigger period that is included in the data analysis.

For more information see [chapter 3.3.4, "Using Pre- and Posttrigger"](#), on page 39.

**Auto Rearm**

Immediately rearms the trigger after a measurement has been triggered.

Any further trigger events trigger a new measurement. Displayed data will be overwritten.

Remote command:

[TRIGger:MODE](#) on page 95

**Stop On Trigger**

Stops the measurement after a measurements has been triggered.

Any further trigger events are ignored. Displayed data remains.

Remote command:

[TRIGger:MODE](#) on page 95

## 5 Analysis

### 5.1 Working with Traces

Trace 1 to 4.....	60
L Clear Write.....	60
L Max Hold.....	60
L Min Hold.....	61
L View.....	61
L Blank.....	61
L Detector.....	61
L Positive Peak.....	61
L Negative Peak.....	62
L Average.....	62
Copy Trace.....	62
Trace Wizard.....	62
ASCII Trace Export.....	62
Decim Sep.....	62

#### Trace 1 to 4

Selects the active trace (1, 2, 3 or 4) and opens the "Trace Mode" submenu for the selected trace.

Note that in Spectrum mode, 6 traces are available.

The default setting is trace 1 in the overwrite mode (see "Clear Write" on page 60), the other traces are switched off (see "Blank" on page 61).

**Tip:** To configure several traces in one step, use the functionality of the Trace Configuration dialog box. To access the dialog box, press the [Trace Wizard](#) softkey.

Note that in the Spectrogram and Persistence Spectrum result displays only one trace is available. In the Persistence Spectrum, this is the Realtime trace.

Remote command:

Selected via numeric suffix of: TRACe<n> commands

#### Clear Write ← Trace 1 to 4

Overwrite mode: the trace is overwritten by each sweep. This is the default setting.

Remote command:

DISP:TRAC:MODE WRIT, see [DISPlay\[:WINDow<n>\]:TRACe<t>:MODE](#) on page 104

#### Max Hold ← Trace 1 to 4

The maximum value is determined over several sweeps and displayed. The R&S ESR saves the sweep result in the trace memory only if the new value is greater than the previous one.

This mode is especially useful with modulated or pulsed signals. The signal spectrum is filled up upon each sweep until all signal components are detected in a kind of envelope.

Remote command:

DISP:TRAC:MODE MAXH, see [DISPlay\[:WINDow<n>\]:TRACe<t>:MODE](#)  
on page 104

#### **Min Hold ← Trace 1 to 4**

The minimum value is determined from several measurements and displayed. The R&S ESR saves the smallest of the previously stored/currently measured values in the trace memory.

This mode is useful e.g. for making an unmodulated carrier in a composite signal visible. Noise, interference signals or modulated signals are suppressed whereas a CW signal is recognized by its constant level.

Remote command:

DISP:TRAC:MODE MINH, see [DISPlay\[:WINDow<n>\]:TRACe<t>:MODE](#)  
on page 104

#### **View ← Trace 1 to 4**

The current contents of the trace memory are frozen and displayed.

**Note:** If a trace is frozen, the instrument settings, apart from level range and reference level (see below), can be changed without impact on the displayed trace. The fact that the displayed trace no longer matches the current instrument setting is indicated by the  icon on the tab label.

If the level range or reference level is changed, the R&S ESR automatically adapts the measured data to the changed display range. This allows an amplitude zoom to be made after the measurement in order to show details of the trace.

Remote command:

DISP:TRAC:MODE VIEW, see [DISPlay\[:WINDow<n>\]:TRACe<t>:MODE](#)  
on page 104

#### **Blank ← Trace 1 to 4**

Hides the selected trace.

Remote command:

DISP:TRAC OFF, see [DISPlay\[:WINDow<n>\]:TRACe<t>\[:STATE\]](#) on page 105

#### **Detector ← Trace 1 to 4**

Opens a submenu to select the detector.

#### **Positive Peak ← Detector ← Trace 1 to 4**

Selects the "Positive Peak" detector.

Remote command:

DET POS, see [\[SENSe:\] \[WINDow:\] DETector<trace>\[:FUNCTION\]](#)  
on page 106

**Negative Peak ← Detector ← Trace 1 to 4**

Selects the "Negative Peak" detector.

Remote command:

DET NEG, see [SENSe:] [WINDow:] DETector<trace>[:FUNCTION]

on page 106

**Average ← Detector ← Trace 1 to 4**

Selects the "Average" detector.

Remote command:

DET AVER, see [SENSe:] [WINDow:] DETector<trace>[:FUNCTION]

on page 106

**Copy Trace**

Opens an edit dialog box to enter the number of the trace memory in which the currently selected trace will be copied.

Remote command:

TRACe<n>:COPY on page 107

**Trace Wizard**

Opens the Trace Wizard dialog. For more information see the manual of the R&S ESR.

**ASCII Trace Export**

Opens the "ASCII Trace Export Name" dialog box and saves the active trace in ASCII format to the specified file and directory.

The file consists of the header containing important scaling parameters and a data section containing the trace data. For details on an ASCII file see [chapter 3.6, "ASCII File Export Format"](#), on page 43.

This format can be processed by spreadsheet calculation programs, e.g. MS-Excel. It is necessary to define ';' as a separator for the data import. Different language versions of evaluation programs may require a different handling of the decimal point. It is therefore possible to select between separators '.' (decimal point) and ',' (comma) using the "Decim Sep" softkey (see ["Decim Sep"](#) on page 62).

Remote command:

FORMat:DEXPort:DSEPARATOR on page 106

MMEMory:STORe<n>:TRACe on page 106

**Decim Sep**

Selects the decimal separator with floating-point numerals for the ASCII Trace export to support evaluation programs (e.g. MS-Excel) in different languages. The values '.' (decimal point) and ',' (comma) can be set.

Remote command:

FORMat:DEXPort:DSEPARATOR on page 106

## 5.2 Using Markers

### 5.2.1 Configuring Markers

Marker 1 / Marker 2 / Marker 3 / ... Marker 16,/ Marker Norm/Delta.....	63
More Markers.....	63
(Current Maxhold).....	63
Marker to Trace.....	64
Marker Wizard.....	64
L All Marker Off.....	65
All Marker Off.....	65
Marker Table.....	65
Marker Stepsize.....	65
L Stepsize Standard.....	65
L Stepsize Sweep Points.....	66
Marker Info (On Off).....	66

#### Marker 1 / Marker 2 / Marker 3 / ... Marker 16,/ Marker Norm/Delta

The "Marker X" softkey activates the corresponding marker and opens an edit dialog box to enter a value for the marker to be set to. Pressing the softkey again deactivates the selected marker.

If a marker value is changed using the rotary knob, the step size is defined via the [Stepsize Standard](#) or [Stepsize Sweep Points](#) softkeys.

Marker 1 is always the reference marker for relative measurements. If activated, markers 2 to 16 are delta markers that refer to marker 1. These markers can be converted into markers with absolute value display using the "Marker Norm/Delta" softkey. If marker 1 is the active marker, pressing the "Marker Norm/Delta" softkey switches on an additional delta marker.

Remote command:

[CALCulate<n>:MARKer<m>\[:STATe\]](#) on page 109

[CALCulate<n>:MARKer<m>:X](#) on page 110

[CALCulate<n>:MARKer<m>:Y](#) on page 111

[CALCulate<n>:DELTAmarker<m>\[:STATe\]](#) on page 113

[CALCulate<n>:DELTAmarker<m>:X](#) on page 114

[CALCulate<n>:DELTAmarker<m>:X:RELative](#) on page 114

[CALCulate<n>:DELTAmarker<m>:Y](#) on page 115

#### More Markers

Opens a sub-menu to select one of up to 16 available markers. See "[Marker 1 / Marker 2 / Marker 3 / ... Marker 16,/ Marker Norm/Delta](#)" on page 63.

#### (Current Maxhold)

Selects the trace (current or maxhold) the marker is positioned on.

Available for the persistence spectrum.

Remote command:

[CALCulate<n>:MARKer<m>:TRACe](#) on page 109

### Marker to Trace

Opens an edit dialog box to enter the number of the trace on which the marker is to be placed.

Remote command:

[CALCulate<n>:MARKer<m>:TRACe](#) on page 109

[CALCulate<n>:DELTAmarker<m>:TRACe](#) on page 113

### Marker Wizard

Opens a configuration dialog for markers. The marker wizard allows you to configure and activate up to 16 different markers in one dialog. The first 8 markers are displayed on one tab, the last 8 markers on a second tab. For each marker, the following settings are available:

Selected	State	Type	Ref. Marker	Trace
Marker 1	<input checked="" type="checkbox"/> On/Off	Normal Delta	to	1
Delta 1	<input checked="" type="checkbox"/> On/Off	Normal Delta	to 1	1
Delta 2	<input checked="" type="checkbox"/> On/Off	Normal Delta	to 1	1
Delta 3	<input checked="" type="checkbox"/> On/Off	Normal Delta	to 1	1
Delta 4	<input checked="" type="checkbox"/> On/Off	Normal Delta	to 1	1
Delta 5	<input checked="" type="checkbox"/> On/Off	Normal Delta	to 1	1
Delta 6	<input type="checkbox"/> On/Off	Normal Delta	to 1	1
Delta 7	<input type="checkbox"/> On/Off	Normal Delta	to 1	1
Delta 8	<input type="checkbox"/> On/Off	Normal Delta	to 1	1

All Marker Off

"Selected/State" When you press the "Selected" or "State" field the corresponding marker is activated and the marker row is highlighted.

"Normal/Delta" Defines whether it is a normal marker or delta marker. For delta markers you can define a reference marker.

"Ref. Marker" Reference marker for delta markers. The marker values for the delta marker are indicated relative to the specified reference marker.



"Trace" Trace for which the marker is to be set.

Remote command:

[CALCulate<n>:MARKer<m>\[:STATe\]](#) on page 109

[CALCulate<n>:DELTamarker<m>\[:STATe\]](#) on page 113

[CALCulate<n>:MARKer<m>:TRACe](#) on page 109

[CALCulate<n>:DELTamarker<m>:TRACe](#) on page 113

[CALCulate<n>:DELTamarker<m>:MREF](#) on page 113

#### All Marker Off ← Marker Wizard

Switches all markers off. It also switches off all functions and displays that are associated with the markers/delta markers.

Remote command:

[CALCulate<n>:MARKer<m>:AOFF](#) on page 108

#### All Marker Off

Switches all markers off. It also switches off all functions and displays that are associated with the markers/delta markers.

Remote command:

[CALCulate<n>:MARKer<m>:AOFF](#) on page 108

#### Marker Table

Defines how the marker information is displayed.

"On" Displays the marker information in a table in a separate area beneath the diagram.

"Off" Displays the marker information within the diagram area.

"Aut" (Default) The marker table is displayed automatically if more than 2 markers are active, and removed if only 1 or 2 markers are active. This helps keep the information in the display clear.

Remote command:

[DISPlay:MTABLE](#) on page 115

#### Marker Stepsize

Opens a submenu to set the step size of all markers and delta markers.

Default value for the marker step size is [Stepsize Sweep Points](#).

#### Stepsize Standard ← Marker Stepsize

Moves the marker or delta marker from one measurement point to the next, if the marker or delta marker value is changed via the rotary knob ( "Marker 1 / Marker 2 / Marker 3 / ... Marker 16,/ Marker Norm/Delta" softkeys, see ["Marker 1 / Marker 2 / Marker 3 / ... Marker 16,/ Marker Norm/Delta"](#) on page 63). If more measured values than measurement points exist, it is not possible to read out all measured values. In this case, use the [Stepsize Sweep Points](#) softkey.

Remote command:

[CALC:MARK:X:SSIZ STAN](#) (see [CALCulate<n>:MARKer<m>:X:SSIZe](#) on page 110)

**Stepsize Sweep Points ← Marker Stepsize**

Moves the marker or delta marker from one measured value to the next, if the marker or delta marker value is changed via the rotary knob ( "Marker 1 / Marker 2 / Marker 3 / ... Marker 16,/ Marker Norm/Delta" softkeys, see "[Marker 1 / Marker 2 / Marker 3 / ... Marker 16,/ Marker Norm/Delta](#)" on page 63). If more measured values than measurement points exist, every single measured value is accessible and its value is displayed in the marker field.

The number of measured values is defined by the measurement bandwidth.

Remote command:

CALC:MARK:X:SSIZ POIN (see [CALCulate<n>:MARKer<m>:X:SSIZe](#) on page 110)

**Marker Info (On Off)**

Turns the display of the marker information in the diagram area on and off.

**5.2.2 Positioning Markers**

Peak.....	66
Next Peak.....	66
Center =Mkr Freq (span > 0).....	67
Ref Lvl =Mkr Lvl.....	67
Marker to Trace.....	67
Min.....	67
Next Min.....	67
Auto Max Peak/Auto Min Peak.....	67
Search Limits.....	67
L Left Limit.....	68
L Right Limit.....	68
L Threshold.....	68
L Use Zoom Limits.....	68
L Search Lim Off.....	68
Next Mode.....	68
Exclude LO.....	69

**Peak**

Sets the active marker/delta marker to the highest maximum of the trace.

Remote command:

[CALCulate<n>:MARKer<m>:MAXimum\[:PEAK\]](#) on page 118

**Next Peak**

Sets the active marker/delta marker to the next maximum of the selected trace.

Remote command:

[CALCulate<n>:MARKer<m>:MAXimum:NEXT](#) on page 118

[CALCulate<n>:DELTAmarker<m>:MAXimum:NEXT](#) on page 127

**Center =Mkr Freq (span > 0)**

Sets the center frequency to the current marker or delta marker frequency. A signal can thus be set to as center frequency, for example to examine it in detail with a smaller span.

Remote command:

[CALCulate<n>:MARKer<m>:FUNction:CENTer](#) on page 116

**Ref Lvl =Mkr Lvl**

Sets the reference level to the current marker level.

Remote command:

[CALCulate<n>:MARKer<m>:FUNction:REFerence](#) on page 116

**Marker to Trace**

Opens an edit dialog box to enter the number of the trace on which the marker is to be placed.

Remote command:

[CALCulate<n>:MARKer<m>:TRACe](#) on page 109

[CALCulate<n>:DELTAmarker<m>:TRACe](#) on page 113

**Min**

Sets the active marker/delta marker to the minimum of the selected trace.

Remote command:

[CALCulate<n>:MARKer<m>:MINimum\[:PEAK\]](#) on page 120

**Next Min**

Sets the active marker/delta marker to the next minimum of the selected trace.

Remote command:

[CALCulate<n>:MARKer<m>:MINimum:NEXT](#) on page 120

[CALCulate<n>:DELTAmarker<m>:MINimum:NEXT](#) on page 129

**Auto Max Peak/Auto Min Peak**

Adds an automatic peak search action for marker 1 at the end of each particular sweep. This function may be used during adjustments of a device under test to keep track of the current peak marker position and level.

The current marker search limit settings ([Left Limit](#), [Right Limit](#), [Threshold](#) softkeys) are taken into account.

Remote command:

[CALCulate<n>:MARKer<m>:MAXimum:AUTO](#) on page 117

[CALCulate<n>:MARKer<m>:MINimum:AUTO](#) on page 119

**Search Limits**

Opens a submenu to set the limits for maximum or minimum search in the x and y direction.

Remote command:

[CALCulate<n>:MARKer<m>:X:SLIMits\[:STATe\]](#) on page 137

**Left Limit ← Search Limits**

Opens an edit dialog box to enter a value for the lower limit (left vertical line: S1 for span > 0; T1 for zero span). The search is performed between the lines of the left and right limit (see also [Right Limit](#) softkey).

Remote command:

`CALCulate<n>:MARKer<m>:X:SLIMits:LEFT` on page 136

**Right Limit ← Search Limits**

Opens an edit dialog box to enter a value for the upper limit (left vertical line: S2 for span > 0; T2 for zero span). The search is performed between the lines of the left and right limit (see also [Left Limit](#) softkey). If no value is set, the upper limit corresponds to the stop frequency.

Remote command:

`CALCulate<n>:MARKer<m>:X:SLIMits:RIGHT` on page 137

**Threshold ← Search Limits**

Opens an edit dialog box to define the threshold line. The threshold line represents the lower level limit for a "Peak" search and the upper level limit for a "Min" search.

Remote command:

`CALCulate<n>:THReshold:STATe` on page 138

`CALCulate<n>:THReshold` on page 138

**Use Zoom Limits ← Search Limits**

Restricts the marker search to the zoomed area.

Note that the marker zoom is only available in Spectrum mode.

Remote command:

`CALCulate<n>:MARKer<m>:X:SLIMits:ZOOM` on page 138

**Search Lim Off ← Search Limits**

Deactivates all limits of the search range.

Remote command:

`CALCulate<n>:MARKer<m>:X:SLIMits[:STATe]` on page 137

`CALCulate<n>:THReshold:STATe` on page 138

**Next Mode**

Selects the mode of the [Next Peak](#) or [Next Min](#) softkey.

Three settings are available:

- |       |   |
|-------|---|
| "<"   | Sets the active marker/delta marker to the next maximum/minimum left to the marker of the selected trace. |
| "abs" | Sets the active marker/delta marker to the next lower maximum/higher minimum of the selected trace.       |

">" Sets the active marker/delta marker to the next maximum/minimum right to the marker of the selected trace.

Remote command:

**Next Peak:**

CALC:MARK:MAX:LEFT (<): [CALCulate<n>:MARKer<m>:MAXimum:LEFT](#)  
on page 117

[CALCulate<n>:DELTamarker<m>:MAXimum:LEFT](#) on page 127

CALC:MARK:MAX:RIGH (>): [CALCulate<n>:MARKer<m>:MAXimum:RIGHT](#)  
on page 118

[CALCulate<n>:DELTamarker<m>:MAXimum:RIGHT](#) on page 128

CALC:DELT:MAX:NEXT (abs): [CALCulate<n>:MARKer<m>:MAXimum:NEXT](#)  
on page 118

[CALCulate<n>:DELTamarker<m>:MAXimum:NEXT](#) on page 127

**Next Min:**

CALC:MARK:MIN:LEFT (>): [CALCulate<n>:MARKer<m>:MINimum:LEFT](#)  
on page 119

[CALCulate<n>:DELTamarker<m>:MINimum:LEFT](#) on page 129

CALC:MARK:MIN:RIGH (>): [CALCulate<n>:MARKer<m>:MINimum:RIGHT](#)  
on page 121

[CALCulate<n>:DELTamarker<m>:MINimum:RIGHT](#) on page 130

CALC:MARK:MIN:NEXT (abs): [CALCulate<n>:MARKer<m>:MINimum:NEXT](#)  
on page 120

[CALCulate<n>:DELTamarker<m>:MINimum:NEXT](#) on page 129

**Exclude LO**

Switches the frequency range limit for the marker search functions on or off.

"ON" The minimum frequency included in the peak search range is  $\geq 5 \times$  resolution bandwidth (RBW).  
Due to the interference by the first local oscillator to the first intermediate frequency at the input mixer, the LO is represented as a signal at 0 Hz. To avoid the peak marker jumping to the LO signal at 0 Hz, this frequency is excluded from the peak search.

"OFF" No restriction to the search range. The frequency 0 Hz is included in the marker search functions.

Remote command:

[CALCulate<n>:MARKer<m>:LOEXclude](#) on page 109

## 6 Remote Control Commands

- [Selecting the Operating Mode](#).....70
- [Measurements and Result Displays](#).....71
- [Configuration](#).....83
- [Analysis](#).....103
- [Status Registers](#).....139

### 6.1 Selecting the Operating Mode

<a href="#">INSTrument:CREate[:NEW]</a> .....	70
<a href="#">INSTrument:DELeTe</a> .....	70
<a href="#">INSTrument[:SELeCt]</a> .....	71

---

#### **INSTrument:CREate[:NEW]** <ChannelType>, <ChannelName>

This command adds an additional spectrum display. You can add up to three additional spectrum displays.

Also see

- [INSTrument\[:SELeCt\]](#) on page 71
- [INSTrument:DELeTe](#) on page 70

#### **Parameters:**

<ChannelType>

#### **SANalyzer**

The channel type is always `SANalyzer` to indicate that you add a new spectrum display.

<ChannelName>

Sets the name of the additional spectrum display.

#### **Spectrum 2 | Spectrum 3 | Spectrum 4**

The names of the spectrum displays you add have to be `Spectrum 2` for the second spectrum display, `Spectrum 3` for the third and `Spectrum 4` for the fourth.

#### **Example:**

```
INST:CRE SAN, Spectrum 2
```

Adds a second spectrum display.

---

#### **INSTrument:DELeTe** <ChannelName>

This command deletes a spectrum display.

Also see

- [INSTrument:CREate\[:NEW\]](#) on page 70

**Parameters:**

<ChannelName> Selects the spectrum display you want to delete.

**Spectrum 2 | Spectrum 3 | Spectrum 4**

A spectrum display must exist in order to be able delete it.

**Example:**

```
INST:DEL Spectrum 4
```

Deletes the fourth spectrum display.

**INSTrument[:SElect] <Mode> | <ChannelName>**

This command activates a new measurement channel with the defined channel type, or selects an existing measurement channel with the specified name.

- [INSTrument:CREate\[:NEW\]](#) on page 70

**Parameters:**

<Mode>

**RECeiver**

Receiver mode

**RTIME**

Realtime mode

**SANalyzer**

Spectrum mode

**Spectrum 2 | Spectrum 3 | Spectrum 4**

Selects one of the additional spectrum displays. The first spectrum display is always active. You can select it with `SANalyzer`.

A spectrum display must exist in order to be able to select it.

```
*RST: SANalyzer
```

## 6.2 Measurements and Result Displays

### 6.2.1 Configuring Real-Time Measurements

<a href="#">[SENSe&lt;n&gt;]:SWEep:FFT:WINDow:TYPE</a> .....	71
<a href="#">CALCulate&lt;n&gt;:FEED</a> .....	72
<a href="#">DISPlay:WINDow[:SUBWindow]:ZOOM:AREA</a> .....	72
<a href="#">DISPlay:WINDow[:SUBWindow]:ZOOM:STATe</a> .....	73

**[SENSe<n>]:SWEep:FFT:WINDow:TYPE <FFTWindow>**

This command selects the type of FFT window that you want to use in realtime mode.

**Parameters:**

<FFTWindow>      **BLACk**harris  
**FLAT**top  
**GAUS**sian  
**HANN**ing  
**KAIS**erbessel  
**RECT**angular  
 \*RST:      BLACk

**Example:**

SWE:FFT:WIND:TYPE HANN  
 Selects the Hanning FFT window.

**Mode:**

RT

**CALCulate**<n>:**FEED** <ResultDisplay>

This command selects the result display in realtime mode.

**Parameters:**

<ResultDisplay>    **'XF**requency:**RF**Power[:**SPEC**trum]'  
**'XF**requency[:**SPEC**trum]'  
 Selects the realtime spectrum result display.  
**'XF**requency:**RF**Power:**SGR**am'  
**'XF**requency:**SGR**am'  
 Selects the spectrogram result display.  
**'XF**requency:**RF**Power:**PS**pectrum'  
**'XF**requency:**PS**pectrum'  
 Selects the persistence spectrum result display.  
 \*RST:      **SPEC**trum

**Example:**

CALC:FEED 'XFR:PSP'  
 Starts the persistence spectrum result display.

**DIS**play:**WIND**ow[:**SUB**Window]:**ZOOM**:**AREA** <StartFrequency>, <StartTime>, <StopFrequency>, <StopTime>

This command defines the zoom area.

Before you can use this command, you have to turn the zoom on with [DIS](#)play:  
[WIND](#)ow[:**SUB**Window]:**ZOOM**:**STATE** on page 73.

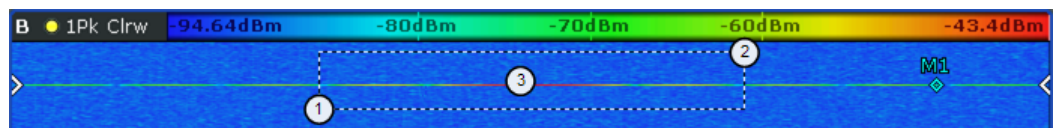

1 = Start frequency and time  
 2 = Stop frequency and time  
 3 = Zoom area



**Parameters:**

<StartFrequency>	Defines the start frequency of the zoom area. The range depends on the span of the unzoomed spectrogram.
<StartTime>	Defines the start time of the zoom area. Time information in seconds is relative to the present frame. The range corresponds to the visible spectrogram.
<StopFrequency>	Defines the stop frequency of the zoom area. The range depends on the span of the unzoomed spectrogram.
<StopTime>	Defines the stop time of the zoom area. Time information in seconds is relative to the present frame. The range corresponds to the visible spectrogram.

**Example:**

DISP:WIND:ZOOM:AREA 95MHZ,-2s,105MHZ,-1s  
Defines a zoom area between 95 and 105 MHz and between -1 and -2 seconds ago.

**Mode:** RT

**DISPlay:WINDow[:SUBWindow]:ZOOM:STATE <State>**

This command turns the spectrogram zoom on and off.

The spectrogram has to be active for the command to work.

**Parameters:**

<State> ON | OFF

**Example:**

DISP:WIND:ZOOM:STAT ON  
Turns the zoom on.

## 6.2.2 Using the Persistence Spectrum Result Display

### 6.2.2.1 Configuring the Persistence Spectrum

DISPlay:WINDow[:SUBWindow]:TRACe:MAXHold:RESet.....	73
DISPlay:WINDow<n>[:SUBWindow<m>]:TRACe<t>:MAXHold[:INTensity].....	74
DISPlay:WINDow<n>[:SUBWindow<m>]:TRACe:MAXHold[:STATE].....	74
DISPlay:WINDow<n>[:SUBWindow<m>]:TRACe<t>:PERSistence:DURation.....	74
DISPlay:WINDow[:SUBWindow]:TRACe:PERSistence:GRANularity.....	74
DISPlay:WINDow<n>[:SUBWindow<m>]:TRACe<t>:PERSistence[:STATE].....	75
DISPlay:WINDow<n>[:SUBWindow<m>]:TRACe<t>:SYMBOL.....	75

**DISPlay:WINDow[:SUBWindow]:TRACe:MAXHold:RESet**

This command resets the maxhold trace in the persistence spectrum result display.

**Usage:** Event

**Mode:** RT

---

**DISPlay:WINDow<n>[:SUBWindow<m>]:TRACe<t>:MAXHold[:INTensity]**  
<intensity> | RESet

This command defines the color intensity of the maxhold persistence spectrum.

**Parameters:**

<intensity>                Sets the color intensity of the maxhold trace.  
Setting an intensity of 0 turns the maxhold off.  
Range:            0 to 254  
Increment:       1  
\*RST:            100

RESet                      Resets the maxhold trace.

**Example:**                DISP:WIND:TRAC:MAXH 120  
Sets the color intensity of the maxhold trace to 120.  
DISP:WIND:TRAC:MAXH RES  
Resets the maxhold trace.

**Mode:**                    RT

---

**DISPlay:WINDow<n>[:SUBWindow<m>]:TRACe:MAXHold[:STATe]** <boolean>

This command switches the maxhold trace in the persistence spectrum on and off.

**Parameters:**

<boolean>                **ON | OFF**  
\*RST:            On

**Mode:**                    RT

---

**DISPlay:WINDow<n>[:SUBWindow<m>]:TRACe<t>:PERSistence:DURation**  
<persistence>

This command sets the duration of the persistence.

Setting the persistence to 0 turns it off.

**Parameters:**

<persistence>           Persistence in seconds.  
Range:            0 to 8  
Increment:       0.001  
\*RST:            1 seconds  
Default unit: seconds

**Example:**                DISP:WIND:TRAC:PERS:DUR 4.3  
Sets the persistence to 4.3 seconds.

**Mode:**                    RT

---

**DISPlay:WINDow[:SUBWindow]:TRACe:PERSistence:GRANularity** <Granularity>

This command sets the persistence granularity

**Parameters:**

<Granularity> Amount of data the R&S ESR uses to build the persistence spectrum in seconds.

\*RST: RST value

**Mode:** RT

**DISPlay:WINDow<n>[:SUBWindow<m>]:TRACe<t>:PERSistence[:STATe]**  
<boolean>

This command switches persistence in the persistence spectrum on and off.

**Parameters:**

<boolean> ON | OFF

\*RST: On

**Mode:** RT

**DISPlay:WINDow<n>[:SUBWindow<m>]:TRACe<t>:SYMBOL** <style>

This command sets the display style of the persistence spectrum.

**Parameters:**

<style>

**DOTS**

Displays the data as dots. The result is a persistence spectrum made up out of dots.

**VECTor**

Interpolates the measurement points. The result is an uninterrupted persistence spectrum.

\*RST: VECTor

**Example:**

CALC3:FEED 'XFR:HIST'

Activates the persistence spectrum in screen 3 with a vectorial display of the results.

DISP:WIND3:TRAC:SYMB DOTS

Displays the persistence spectrum in the third measurement screen as dots.

**Mode:** RT

### 6.2.2.2 Working with the Color Map

|  |    |
|--|----|
| DISPlay:WINDow:PSPectrum:COLor:DEFault.....  | 76 |
| DISPlay:WINDow:PSPectrum:COLor:LOWer.....    | 76 |
| DISPlay:WINDow:PSPectrum:COLor:SHAPE.....    | 76 |
| DISPlay:WINDow:PSPectrum:COLor:TRUNcate..... | 76 |
| DISPlay:WINDow:PSPectrum:COLor:UPPer.....    | 76 |
| DISPlay:WINDow:PSPectrum:COLor[:STYLe].....  | 77 |

**DISPlay:WINDow:PSPectrum:COLor:DEFault**

This command sets the color settings for the persistence spectrum result display to its default state.

**Usage:** Event

**DISPlay:WINDow:PSPectrum:COLor:LOWer <Percentage>**

This command sets the lower percentage boundary of the persistence spectrum.

**Parameters:**

<Percentage> Statistical frequency percentage.  
 Range: 0 to 65,6  
 \*RST: 0  
 Default unit: %

**Example:**

DISP:WIND:HIST:COL:LOW 10  
 Sets the start of the color map to 10%.

**DISPlay:WINDow:PSPectrum:COLor:SHAPE <Shape>**

This command defines the shape and focus of the color curve for the persistence spectrum result display.

**Parameters:**

<Shape> Shape of the color curve.  
 Range: -1 to 1  
 \*RST: 0

**DISPlay:WINDow:PSPectrum:COLor:TRUNcate <State>**

This command reduces the range of the color map of the persistence spectrum if there are no hits at the start or end of the value range.

**Parameters:**

<State> **ON**  
**OFF**  
 \*RST: OFF

**Example:**

DISP:WIND:PSP:COL:TRUN ON  
 Activates truncation of the color map.

**DISPlay:WINDow:PSPectrum:COLor:UPPer <Percentage>**

This command sets the upper percentage boundary of the persistence spectrum.

**Parameters:**

<Percentage> Statistical frequency percentage.  
 Range: 0 to 66  
 \*RST: 0  
 Default unit: %

**Example:**

DISP:WIND:HIST:COL:UPP 95  
 Sets the start of the color map to 95%.

**DISPlay:WINDow:PSPectrum:COLor[:STYLE] <ColorScheme>**

This command sets the color scheme for the persistence spectrum.

**Parameters:**

<ColorScheme> **HOT**  
**COLD**  
**RADar**  
**GREYscale**  
 \*RST: HOT

**Example:**

DISP:WIND:HIST:COL GREY  
 Changes the color scheme of the persistence spectrum to black and white.

## 6.2.3 Using the Spectrogram Result Display

### 6.2.3.1 Configuring the Spectrogram

**CALCulate<n>:SGRam:CLEar[:IMMediate]**

This command resets the Spectrogram result display and clears the history buffer.

**Suffix:**

<n> 1...4  
 Selects the measurement window.

**Example:**

CALC:SGR:CLE  
 Resets the result display and clears the memory.

**Usage:**

Event

**CALCulate<n>:SGRam:CONT <State>**

This command determines whether the results of the last measurement are deleted before starting a new measurement in single sweep mode.

**Suffix:**

<n> 1...4  
 Selects the measurement window.

**Parameters:**<State> **ON | OFF**

\*RST: OFF

**Example:**

INIT:CONT OFF

Selects single sweep mode.

INIT;\*WAI

Starts the sweep and waits for the end of the sweep.

CALC:SGR:CONT ON

Repeats the single sweep measurement without deleting the results of the last measurement.

**CALCulate<n>:SGRam:FRAMe:COUnT <Frames>**

This command sets the number of frames to be recorded in a single sweep.

**Suffix:**

&lt;n&gt; 1...4

Selects the measurement window.

**Parameters:**

&lt;Frames&gt;

The maximum number of frames depends on the .  
[CALCulate<n>:SGRam:HDEPth](#) on page 79

Range: 1 to depends on history depth

Increment: 1

\*RST: 1

**Example:**

INIT:CONT OFF

Selects single sweep mode.

CALC:SGR:FRAM:COUn 200

Sets the number of frames to 200.

**CALCulate<n>:SGRam:FRAMe:SELEct <Frame>**

This command selects a specific frame for further analysis. The command is available only if no measurement is running or after a single sweep has ended.

**Suffix:**

&lt;n&gt; 1...4

Selects the measurement window.

**Parameters:**

&lt;Frame&gt;

**<frame\_number> (if time stamp is off)**

Selects the frame. The range is {0...number of recorded frames-1}

**<time> (if time stamp is on)**

Time distance in seconds. It selects the frame that is x seconds away from frame 0.

**Example:**

INIT:CONT OFF

Stop the continuous sweep.

CALC:SGR:FRAM:SEL -25

Selects frame number -25.

**CALCulate<n>:SGRam:HDEPth <HistoryDepth>**

This command sets the number of frames to be stored in the R&S ESR's memory.

**Suffix:**

<n> 1...4  
Selects the measurement window.

**Parameters:**

<HistoryDepth> The maximum number of frames depends on the number of sweep points.  
Range: 781 to 20000  
Increment: 1  
\*RST: 3000

**Example:**

CALC:SGR:HDEP 1500  
Sets the history depth to 1500.

**CALCulate<n>:SGRam:TSTamp:DATA? <Mode>**

This command queries the time stamp of the frames.

All available frame results are returned by TRACe<n> [:DATA] on page 107.

**Suffix:**

<n> 1...4  
Selects the measurement window.

**Query parameters:**

<Mode> **CURRENT**  
Returns the time stamp of the current frame.

**ALL**

Returns the time stamps of all frames. The result are sorted in descending order, beginning with the current frame.

**Return values:**

<TimeStamp> The return values consist of four values for each frame. The first value is the date of the measurement in seconds that have passed since 01.01.1970 in seconds. For a better resolution the second value shows the additional milliseconds. This value is also displayed on screen. These numbers are appropriate for relative uses, but you can also calculate the absolute date and time as displayed on the screen. The third and fourth value are reserved for future uses. If the Spectrogram is empty, the command returns '0,0,0,0'

**Example:**

CALC:SGR:TST ON  
Activates the time stamp.  
CALC:SGR:TST:DATA? ALL  
Returns the time stamp of all frames sorted in a descending order.

**Usage:** Query only

**CALCulate<n>:SGRam:TSTamp[:STATe] <State>**

This command activates and deactivates the time stamp.

If the time stamp is active, some commands do not address frames as numbers, but as (relative) time values:

- [CALCulate<n>:DELTaMarker<m>:SGRam:FRAMe](#) on page 131
- [CALCulate<n>:MARKer<m>:SGRam:FRAMe](#) on page 121
- [CALCulate<n>:SGRam:FRAMe:SElect](#) on page 78

**Suffix:**

<n> 1...4  
Selects the measurement window.

**Parameters:**

<State> **ON | OFF**  
\*RST: OFF

**Example:**

CALC:SGR:TST ON  
Activates the time stamp.

**CALCulate<n>:SGRam:X:DATA? <Data>**

This command queries the scaling of the x-axis in the spectrogram.

**Parameters:**

<Data> **CURRENT**  
Scaling of the current spectrogram frame.  
**ALL**  
Scaling of all frames in the history of the spectrogram.

**Usage:** Query only

**CALCulate<n>:SGRam[:STATe] <State>**

This command turns the spectrogram result display on and off.

Alternatively, you can turn on the spectrogram with [CALCulate<n>:FEED](#) on page 72.

**Suffix:**

<n> 1...4  
Selects the measurement window.

**Parameters:**

<State> **ON | OFF**  
\*RST: OFF

**Example:**

CALC:SGR ON  
Activates the Spectrogram result display.



**MMEMory:STORe:SGRam <File>**

This command exports the spectrogram data to a ASCII file.

The file contains the data for every frame in the history buffer. The data corresponding to a particular frame begins with information about the frame number and the time that frame was recorded.

Note that, depending on the size of the history buffer, the process of exporting the data can take a while.

**Parameters:**

<File> string containing the file name of the destination file

**Example:**

MMEM:STOR:SGR

Copies the spectrogram data to a file.

**6.2.3.2 Working with the Color Map**

|   |    |
|---|----|
| DISPlay:WINDow:SGRam:COLor:DEFault..... | 81 |
| DISPlay:WINDow:SGRam:COLor:LOWer.....   | 81 |
| DISPlay:WINDow:SGRam:COLor:SHAPE.....   | 81 |
| DISPlay:WINDow:SGRam:COLor:UPPer.....   | 82 |
| DISPlay:WINDow:SGRam:COLor[:STYLE]..... | 82 |

**DISPlay:WINDow:SGRam:COLor:DEFault**

This command sets the color settings for the spectrogram result display to its default state.

**Usage:** Event

**DISPlay:WINDow:SGRam:COLor:LOWer <Percentage>**

This command sets the lower percentage boundary of the spectrogram.

**Parameters:**

<Percentage> Statistical frequency percentage.

Range: 0 to 66

\*RST: 0

Default unit: %

**Example:**

DISP:WIND:SGR:COL:LOW 10

Sets the start of the color map to 10%.

**DISPlay:WINDow:SGRam:COLor:SHAPE <Shape>**

This command defines the shape and focus of the color curve for the spectrogram result display.

**Parameters:**

<Shape>                    Shape of the color curve.  
 Range:            -1 to 1  
 \*RST:            0

**DISPlay:WINDow:SGRam:COLor:UPPer** <Percentage>

This command sets the upper percentage boundary of the spectrogram.

**Parameters:**

<Percentage>            Statistical frequency percentage.  
 Range:            0 to 66  
 \*RST:            0  
 Default unit: %

**Example:**

DISP:WIND:SGR:COL:UPP 95  
 Sets the start of the color map to 95%.

**DISPlay:WINDow:SGRam:COLor[:STYLE]** <ColorScheme>

This command sets the color scheme for the spectrogram.

**Parameters:**

<ColorScheme>            **HOT**  
 Uses a color range from blue to red. Blue colors indicate low levels, red colors indicate high ones.

**COLD**  
 Uses a color range from red to blue. Red colors indicate low levels, blue colors indicate high ones.

**RADar**  
 Uses a color range from black over green to light turquoise with shades of green in between. Dark colors indicate low levels, light colors indicate high ones.

**GRAYscale**  
 Shows the results in shades of gray. Dark gray indicates low levels, light gray indicates high ones.

\*RST:            HOT

**Example:**

DISP:WIND:SGR:COL GRAY  
 Changes the color scheme of the spectrogram to black and white.

## 6.3 Configuration

- [Defining the Horizontal Diagram Axis](#).....83
- [Selecting the Measurement Bandwidth](#).....85
- [Defining Level Characteristics](#).....86
- [Configuring the Sweep](#).....91
- [Triggering Measurements](#).....95

### 6.3.1 Defining the Horizontal Diagram Axis

#### Commands related to the horizontal axis described elsewhere

- [\[SENSe:\]SWEp:TIME](#)

|   |    |
|---|----|
| <a href="#">[SENSe:]FREQuency:CENTer</a> .....                  | 83 |
| <a href="#">[SENSe:]FREQuency:CENTer:STEP</a> .....             | 83 |
| <a href="#">[SENSe:]FREQuency:CENTer:STEP:LINK</a> .....        | 84 |
| <a href="#">[SENSe:]FREQuency:CENTer:STEP:LINK:FACTor</a> ..... | 84 |
| <a href="#">[SENSe:]FREQuency:OFFSet</a> .....                  | 84 |
| <a href="#">[SENSe:]FREQuency:SPAN</a> .....                    | 84 |
| <a href="#">[SENSe:]FREQuency:SPAN:FULL</a> .....               | 85 |
| <a href="#">[SENSe:]FREQuency:START</a> .....                   | 85 |
| <a href="#">[SENSe:]FREQuency:STOP</a> .....                    | 85 |

---

#### **[SENSe:]FREQuency:CENTer** <Frequency>

This command defines the center frequency (frequency domain) or measuring frequency (time domain).

##### Parameters:

<Frequency>            Range:     0 to fmax  
                              \*RST:     fmax/2  
                              Default unit: Hz  
                               $f_{max}$  is specified in the data sheet. min span is 10 Hz

**Example:**            `FREQ:CENT 100 MHz`

---

#### **[SENSe:]FREQuency:CENTer:STEP** <StepSize>

This command defines the center frequency step size.

##### Parameters:

<StepSize>            Range:     1 to fmax  
                              \*RST:     0.1 x <span value>  
                              Default unit: Hz

**Example:**            `FREQ:CENT:STEP 120 MHz`

**[SENSe:]FREQuency:CENTer:STEP:LINK <CouplingType>**

This command couples and decouples the center frequency step size to the span or the resolution bandwidth.

**Parameters:**

&lt;CouplingType&gt;

**SPAN**

Couples the step size to the span. Available for measurements in the frequency domain.

**RBW**

Couples the step size to the resolution bandwidth. Available for measurements in the time domain.

**OFF**

Decouples the step size (manual input).

\*RST: SPAN

**Example:**

FREQ:CENT:STEP:LINK SPAN

**[SENSe:]FREQuency:CENTer:STEP:LINK:FACTOR <Factor>**

This command defines a step size factor if the center frequency step size is coupled to the span or the resolution bandwidth.

**Parameters:**

&lt;Factor&gt;

Range: 1 to 100

\*RST: 10

Default unit: PCT

**Example:**

FREQ:CENT:STEP:LINK:FACT 20PCT

**[SENSe:]FREQuency:OFFSet <Offset>**

This command defines the frequency offset.

**Parameters:**

&lt;Offset&gt;

Range: -100 GHz to 100 GHz

\*RST: 0 Hz

Default unit: Hz

**Example:**

FREQ:OFFS 1GHZ

**[SENSe:]FREQuency:SPAN <Span>**

This command defines the frequency span.

**Parameters:**

&lt;Span&gt;

\*RST: fmax

**Example:**

FREQ:SPAN 10MHz

**[SENSe:]FREQuency:SPAN:FULL**

This command sets the frequency span to its maximum.

**Example:**                   FREQ:SPAN:FULL

**[SENSe:]FREQuency:STARt <Frequency>**

This command defines the start frequency for measurements in the frequency domain.

**Parameters:**

<Frequency>               0 to (fmax - min span)

\*RST:            0

**Example:**               FREQ:STAR 20MHz

**[SENSe:]FREQuency:STOP <Frequency>**

This command defines the stop frequency for measurements in the frequency domain.

**Parameters:**

<Frequency>               min span to fmax

\*RST:            fmax

**Example:**               FREQ:STOP 2000 MHz

## 6.3.2 Selecting the Measurement Bandwidth

### Commands related to the bandwidth described elsewhere

- [\[SENSe:\]SWEp:TIME](#)
- [\[SENSe:\]SWEp:TIME:AUTO](#)

[\[SENSe:\]BANDwidth|BWIDth\[:RESolution\]](#).....85

[\[SENSe:\]BANDwidth|BWIDth\[:RESolution\]:AUTO](#).....86

[\[SENSe:\]BANDwidth|BWIDth\[:RESolution\]:RATio](#).....86

**[SENSe:]BANDwidth|BWIDth[:RESolution] <Bandwidth>**

This command defines the resolution bandwidth.

In realtime mode, the resolution bandwidth is always coupled to the span.

**Parameters:**

<Bandwidth>               refer to data sheet

\*RST:            (AUTO is set to ON)

**Example:**               BAND 1 MHz  
Sets the resolution bandwidth to 1 MHz

**[SENSe:]BANDwidth|BWIDth[:RESolution]:AUTO <State>**

This command couples and decouples the resolution bandwidth to the span.

The automatic coupling adapts the resolution bandwidth to the current frequency span according to the relationship between frequency span and resolution bandwidth.

Use `[SENSe:]BANDwidth|BWIDth[:RESolution]:RATio` to define the ratio RBW/span.

**Parameters:**

<State>                    ON | OFF  
\*RST:                    ON

**Example:**

BAND:AUTO OFF  
Switches off the coupling of the resolution bandwidth to the span.

**[SENSe:]BANDwidth|BWIDth[:RESolution]:RATio <Ratio>**

This command defines the ratio between the resolution bandwidth (Hz) and the span (Hz).

Note that the ratio defined with the remote command (RBW/span) is reciprocal to that of the manual operation (span/RBW).

**Parameters:**

<Ratio>                    Range:        0.0048 to 0.01  
\*RST:                    0.0002

**Example:**

BAND:RAT 0.01

**6.3.3 Defining Level Characteristics**

|   |    |
|---|----|
| CALCulate<n>:UNIT:POWER.....                              | 86 |
| DISPlay[:WINDow<n>]:TRACe<t>:Y[:SCALE].....               | 87 |
| DISPlay[:WINDow<n>]:TRACe<t>:Y[:SCALE]:MODE.....          | 87 |
| DISPlay[:WINDow<n>]:TRACe<t>:Y[:SCALE]:RLEVel.....        | 88 |
| DISPlay[:WINDow<n>]:TRACe<t>:Y[:SCALE]:RLEVel:OFFSet..... | 88 |
| DISPlay[:WINDow<n>]:TRACe<t>:Y:SPACing.....               | 88 |
| INPut:ATTenuation.....                                    | 89 |
| INPut:ATTenuation:AUTO.....                               | 89 |
| INPut:COUpling.....                                       | 89 |
| INPut:GAIN:STATe.....                                     | 89 |
| INPut:IMPedance.....                                      | 90 |
| [SENSe:]POWER:NCORrection.....                            | 90 |

**CALCulate<n>:UNIT:POWER <Unit>**

This command selects the unit of the y-axis.

The unit applies to all measurement windows.

**Suffix:**  
 <n> irrelevant

**Parameters:**  
 <Unit> DBM | V | A | W | DBPW | WATT | DBUV | DBMV | VOLT | DBUA | AMPere  
 \*RST: dBm

**Example:** CALC:UNIT:POW DBM  
 Sets the power unit to dBm.

### DISPlay[:WINDow<n>]:TRACe<t>:Y[:SCALe] <Range>

This command defines the display range of the y-axis with logarithmic scaling.

The command works only for a logarithmic scaling. You can select the scaling with [DISPlay\[:WINDow<n>\]:TRACe<t>:Y:SPACing](#) on page 88.

**Suffix:**  
 <n> window; For applications that do not have more than 1 measurement window, the suffix <n> is irrelevant.

<t> irrelevant

**Parameters:**  
 <Range> Range: 10 to 200  
 \*RST: 100  
 Default unit: dB

**Example:** DISP:TRAC:Y 110dB

### DISPlay[:WINDow<n>]:TRACe<t>:Y[:SCALe]:MODE <Mode>

This command selects the type of scaling of the y-axis.

When `SYSTEM:DISPlay:UPDate` is turned off, this command has no immediate effect on the screen.

**Suffix:**  
 <n> window; For applications that do not have more than 1 measurement window, the suffix <n> is irrelevant.

<t> irrelevant

**Parameters:**  
 <Mode> **ABSolute**  
 absolute scaling of the y-axis  
**RELative**  
 relative scaling of the y-axis  
 \*RST: ABS

**Example:** DISP:TRAC:Y:MODE REL

**DISPlay[:WINDow<n>]:TRACe<t>:Y[:SCALe]:RLEVel <ReferenceLevel>**

This command defines the reference level.

With the reference level offset  $\neq 0$ , the value range of the reference level is modified by the offset.

**Suffix:**

<n> irrelevant.

<t> irrelevant

**Parameters:**

<ReferenceLevel> The unit is variable.  
 Range: see datasheet  
 \*RST: -10dBm

**Example:** DISP:TRAC:Y:RLEV -60dBm

**DISPlay[:WINDow<n>]:TRACe<t>:Y[:SCALe]:RLEVel:OFFSet <Value>**

This command defines a reference level offset.

**Suffix:**

<n> irrelevant.

<t> irrelevant

**Parameters:**

<Value> Range: -200 to 200  
 \*RST: 0  
 Default unit: dB

**Example:** DISP:TRAC:Y:RLEV:OFFS -10dB

**DISPlay[:WINDow<n>]:TRACe<t>:Y:SPACIng <ScalingType>**

This command selects the scaling of the y-axis.

**Suffix:**

<n> Selects the measurement window.

<t> irrelevant

**Parameters:**

<ScalingType> **LOGarithmic**  
 Logarithmic scaling.  
**LINear**  
 Linear scaling in %.  
**LDB**  
 Linear scaling in dB.  
 \*RST: LOGarithmic



**Example:**            `DISP:TRAC:Y:SPAC LIN`  
Select a linear scale.

#### **INPut:ATTenuation** <Value>

This command programs the input attenuator. To protect the input mixer against damage from overloads, the setting 0 dB can be obtained by entering numerals, not by using the DOWN command.

The attenuation can be set in 5 dB steps (with option R&S FSV-B25: 1 dB steps). If the defined reference level cannot be set for the set RF attenuation, the reference level is adjusted accordingly.

In the default state with "Spectrum" mode, the attenuation set on the step attenuator is coupled to the reference level of the instrument. If the attenuation is programmed directly, the coupling to the reference level is switched off.

#### **Parameters:**

<Value>            \*RST:        10 dB (AUTO is set to ON)

#### **Example:**

`INP:ATT 30dB`

Sets the attenuation on the attenuator to 30 dB and switches off the coupling to the reference level.

**Mode:**            all

#### **INPut:ATTenuation:AUTO** <State>

This command automatically couples the input attenuation to the reference level (state ON) or switches the input attenuation to manual entry (state OFF).

#### **Parameters:**

<State>            ON | OFF

\*RST:            ON

#### **Example:**

`INP:ATT:AUTO ON`

Couples the attenuation set on the attenuator to the reference level.

#### **INPut:COUPling** <CouplingType>

Toggles the RF input of the R&S ESR between AC and DC coupling.

#### **Parameters:**

<CouplingType>    AC | DC

\*RST:            AC

#### **Example:**

`INP:COUP:DC`

#### **INPut:GAIN:STATe** <State>

This command turns the 20 dB preamplifier on and off.

**Parameters:**

<State> ON | OFF  
 \*RST: OFF

**Example:**

INP:GAIN:STAT ON  
 Turns the preamplifier on.

**INPut:IMPedance** <Impedance>

This command selects the nominal input impedance.

75  $\Omega$  should be selected if the 50  $\Omega$  input impedance is transformed to a higher impedance using a 75  $\Omega$  adapter of the RAZ type (= 25  $\Omega$  in series to the input impedance of the instrument). The correction value in this case is 1.76 dB = 10 log (75 $\Omega$ /50 $\Omega$ ).

**Parameters:**

<Impedance> 50 | 75  
 \*RST: 50  $\Omega$

**Example:**

INP:IMP 75

**[SENSe:]POWer:NCORrection** <Mode>

This command turns noise cancellation on and off.

If noise cancellation is on, the R&S ESR performs a reference measurement to determine its inherent noise and subtracts the result from the channel power measurement result (first active trace only).

The inherent noise of the instrument depends on the selected center frequency, resolution bandwidth and level setting. Therefore, the correction function is disabled whenever one of these parameters is changed. A corresponding message is displayed on the screen. Noise correction must be turned on again manually after the change.

**Parameters:**

<Mode> **ON**  
 Performs noise correction.

**OFF**  
 Performs no noise correction.

**AUTO**  
 Performs noise correction.  
 After a parameter change, noise correction is restarted automatically and a new correction measurement is performed.

\*RST: OFF

**Example:**

POW:NCOR ON

### 6.3.4 Configuring the Sweep

|                                      |    |
|--------------------------------------|----|
| CALCulate<n>:SGRam:CLEar[:IMMediate] | 91 |
| CALCulate<n>:SGRam:CONT              | 91 |
| CALCulate<n>:SGRam:FRAMe:COUnT       | 91 |
| CALCulate<n>:SGRam:FRAMe:SELEct      | 92 |
| INITiate<n>:CONMeas                  | 92 |
| INITiate<n>:CONTInuous               | 93 |
| INITiate<n>[:IMMediate]              | 93 |
| [SENSe:]SWEep:COUnT                  | 94 |
| [SENSe:]SWEep:TIME                   | 94 |
| [SENSe:]SWEep:TIME:AUTO              | 94 |

---

#### CALCulate<n>:SGRam:CLEar[:IMMediate]

This command resets the Spectrogram result display and clears the history buffer.

**Suffix:**

<n>                    1...4  
Selects the measurement window.

**Example:**

```
CALC:SGR:CLE
Resets the result display and clears the memory.
```

**Usage:**

Event

---

#### CALCulate<n>:SGRam:CONT <State>

This command determines whether the results of the last measurement are deleted before starting a new measurement in single sweep mode.

**Suffix:**

<n>                    1...4  
Selects the measurement window.

**Parameters:**

<State>                **ON | OFF**  
\*RST:                OFF

**Example:**

```
INIT:CONT OFF
Selects single sweep mode.
INIT;*WAI
Starts the sweep and waits for the end of the sweep.
CALC:SGR:CONT ON
Repeats the single sweep measurement without deleting the
results of the last measurement.
```

---

#### CALCulate<n>:SGRam:FRAMe:COUnT <Frames>

This command sets the number of frames to be recorded in a single sweep.

**Suffix:**

<n> 1...4  
Selects the measurement window.

**Parameters:**

<Frames> The maximum number of frames depends on the .  
[CALCulate<n>:SGRam:HDEPth](#) on page 79  
Range: 1 to depends on history depth  
Increment: 1  
\*RST: 1

**Example:**

```
INIT:CONT OFF
Selects single sweep mode.
CALC:SGR:FRAM:COUN 200
Sets the number of frames to 200.
```

**CALCulate<n>:SGRam:FRAM:SElect <Frame>**

This command selects a specific frame for further analysis. The command is available only if no measurement is running or after a single sweep has ended.

**Suffix:**

<n> 1...4  
Selects the measurement window.

**Parameters:**

<Frame> **<frame\_number> (if time stamp is off)**  
Selects the frame. The range is {0...number of recorded frames-1}  
**<time> (if time stamp is on)**  
Time distance in seconds. It selects the frame that is x seconds away from frame 0.

**Example:**

```
INIT:CONT OFF
Stop the continuous sweep.
CALC:SGR:FRAM:SEL -25
Selects frame number -25.
```

**INITiate<n>:CONMeas**

This command restarts a measurement that has been stopped in single sweep mode.

The measurement is restarted at the first sweep point.

As opposed to [INITiate<n>\[:IMMEDIATE\]](#), this command does not reset traces in maxhold, minhold or average mode. Therefore it can be used to continue measurements using max hold or averaging functions.

In single sweep mode, you can synchronize to the end of the measurement with \*OPC, \*OPC? or \*WAI. In continuous sweep mode, synchronization to the end of the measurement is not possible. Thus, it is not recommended that you use continuous sweep mode in remote control, as results like trace data or markers are only valid after a single sweep end synchronization.

**Suffix:**

<n> irrelevant

**Example:**

```
INIT:CONT OFF
```

Switches to single sweep mode.

```
DISP:WIND:TRAC:MODE AVER
```

Switches on trace averaging.

```
SWE:COUN 20
```

Setting the sweep counter to 20 sweeps.

```
INIT;*WAI
```

Starts the measurement and waits for the end of the 20 sweeps.

```
INIT:CONM;*WAI
```

Continues the measurement (next 20 sequences) and waits for the end.

---

**INITiate<n>:CONTInuous <State>**

This command determines whether the trigger system is continuously initiated (continuous) or performs single measurements (single).

**Suffix:**

<n> irrelevant

**Parameters:**

<State> ON | OFF

\*RST: ON

**Mode:**

all

---

**INITiate<n>[:IMMEDIATE]**

The command initiates a new measurement.

In case of a single measurement, the R&S ESR stops measuring when it has reached the end frequency. When you start a continuous measurement, it stops only if you abort it deliberately.

If you are using trace modes MAXHold, MINHold and AVERage, previous results are reset when you restart the measurement.

In single sweep mode, you can synchronize to the end of the measurement with \*OPC, \*OPC? or \*WAI. In continuous sweep mode, synchronization to the end of the measurement is not possible. Thus, it is not recommended that you use continuous sweep mode in remote control, as results like trace data or markers are only valid after a single sweep end synchronization.

**Example:**

```
INIT2:CONT OFF
```

Selects single measurement mode.

```
SWE:COUN 20
```

Forms an average over 20 measurements.

```
INIT2;*WAI
```

Starts the measurement and waits for the end of the complete measurement.

**Usage:** Event

---

**[SENSe:]SWEep:COUNT <NumberSweeps>**

This command defines the number of sweeps started with single sweep, which are used for calculating the average or maximum value. If the values 0 or 1 are set, one sweep is performed.

**Parameters:**

<NumberSweeps> 0 to 32767  
 \*RST: 0 (GSM: 200, PHN:1)

**Example:**

```
SWE:COUN 64
Sets the number of sweeps to 64.
INIT:CONT OFF
Switches to single sweep mode.
INIT;*WAI
Starts a sweep and waits for its end.
```

---

**[SENSe:]SWEep:TIME <Time>**

This command defines the sweep time.

The range depends on the frequency span.

**Parameters:**

<Time> refer to data sheet  
 For R&S ESR spectrum analyzers with an FMR7 CPU board (order no. 1091.3204, with R&S ESR firmware <1.80 only) and 1 GByte RAM the maximum capture time is 600 ms. Otherwise it is 1 s.  
 \*RST: (AUTO is set to ON)

**Example:**

```
SWE:TIME 10s
```

---

**[SENSe:]SWEep:TIME:AUTO <State>**

In realtime mode, this command automatically sets the sweep time to 32 ms.

In analyzer mode, this command controls the automatic coupling of the sweep time to the frequency span and bandwidth settings. If [SENSe:]SWEep:TIME is used, automatic coupling is switched off.

**Parameters:**

<State> ON | OFF  
 \*RST: ON

**Example:**

```
SWE:TIME:AUTO ON
Activates automatic sweep time.
```

## 6.3.5 Triggering Measurements

### 6.3.5.1 Using General Trigger Functions

|  |    |
|--|----|
| TRIGger:MODE.....                          | 95 |
| TRIGger<n>[:SEQuence]:HOLDoff[:TIME].....  | 95 |
| TRIGger<n>[:SEQuence]:SLOPe.....           | 95 |
| TRIGger<n>[:SEQuence]:SOURce.....          | 96 |
| TRIGger<n>[:SEQuence]:TDTRigger:LEVel..... | 96 |
| TRIGger[:SEQuence]:POSTtrigger[:TIME]..... | 97 |
| TRIGger[:SEQuence]:PRETrigger[:TIME].....  | 97 |

---

#### TRIGger:MODE <Mode>

This command turns continuous triggering on and off.

##### Parameters:

|        |  |
|--------|--|
| <Mode> | <b>CONTInuous</b><br>Continuous measurement                      |
|        | <b>STOP</b><br>Measurement stops after the trigger event is done |
|        | *RST:      CONTInuous  |

**Mode:**                    RT

---

#### TRIGger<n>[:SEQuence]:HOLDoff[:TIME] <Delay>

This command defines the length of the trigger delay.

A negative delay time (pretrigger) can be set in zero span only.

##### Suffix:

<n>                            irrelevant

##### Parameters:

|         |  |
|---------|--|
| <Delay> | Range:      zero span: -sweeptime (see data sheet) to 30 s;<br>0 to 30 s |
|         | *RST:      0 s   |

**Example:**                TRIG:HOLD 500us

---

#### TRIGger<n>[:SEQuence]:SLOPe <Type>

This command selects the slope of the trigger signal. The selected trigger slope applies to all trigger signal sources.

##### Suffix:

<n>                            irrelevant

**Parameters:**

<Type> POSitive | NEGative  
 \*RST: POSitive

**Example:** TRIG:SLOP NEG

**TRIGger<n>[:SEQUence]:SOURce <Source>**

This command selects the trigger source.

For details on trigger modes refer to the "Trg/Gate Source" softkey in the base unit description.

**Suffix:**

<n> irrelevant

**Parameters:**

<Source> Note that the availability of the trigger source depends on the measurement you are in.

**EXternal**

Selects an external trigger.

**IFPower**

Selects the trigger on the second intermediate frequency.

**IMMediate**

Selects the free run mode (= no trigger).

**MASK**

Selects the frequency mask trigger.

**TDTRigger**

Selects the time domain trigger.

**TIME**

Selects the time trigger.

**VIDeo**

Selects the video trigger. The video trigger is available for time domain measurements.

\*RST: IMMediate

**Example:** TRIG:SOUR EXT

Selects the external trigger input as source of the trigger signal

**TRIGger<n>[:SEQUence]:TDTRigger:LEVel <TriggerLevel>**

This command sets the trigger level for the time domain trigger.

**Parameters:**

<TriggerLevel> Default unit: dBm

**Example:** TRIG:TDTR:LEV 0

Sets a trigger level of 0 dBm.

**Mode:** RT



**TRIGger[:SEQuence]:POSTtrigger[:TIME] <Time>**

This command defines the length of the posttrigger.

**Parameters:**

<Time> Length of the posttrigger in seconds.  
 Note that the pre- and posttrigger combined may not be longer than 4 seconds.

Range: 0 s to 3 s  
 \*RST: 60 ms

**Example:**

TRIG:POST 1s  
 Selects a posttrigger time of 1 second.

**TRIGger[:SEQuence]:PRETrigger[:TIME] <Time>**

This command defines the length of the pretrigger.

**Parameters:**

<Time> Length of the pretrigger in seconds.  
 Note that the pre- and posttrigger combined may not be longer than 4 seconds.

Range: 0 s to 3 s  
 \*RST: 60 ms

**Example:**

TRIG:PRE 1s  
 Selects a pretrigger time of 1 second.

**6.3.5.2 Using the Frequency Mask Trigger****Programming example**

```
TRIG:SOUR MASK
//Selects the frequency mask as a trigger source.
MMEM:MDIR 'C:\R_S\instr\freqmask\MyMasks'
CALC:MASK:CDIR 'MyMasks'
//Creates a directory on C:\ called 'FreqMasks' and selects it as the frequency
//mask directory.
//Defining the shape of a lower frequency mask
CALC:MASK:NAME 'MyMask'
//Creates or loads a frequency mask called 'MyMask'.
CALC:MASK:COMM 'Customized Frequency Mask'
//Adds a comment to the frequency mask.
TRIG:MASK:COND ENT
//Triggers the measurement when the signal enters the frequency mask.
CALC:MASK:MODE ABS
//Selects absolute power level values.
CALC:MASK:LOW -10MHZ,-10,-4MHZ,-10,-4MHZ,-20,4MHZ,-20,4MHZ,-10,10MHZ,-10
//Defines a lower frequency mask with 6 data points.
//The first data point position is at -10 MHz from the center frequency
```

```

//and at -10 dBm, the second at -4 MHz from the center frequency etc.
CALC:MASK:LOW:SHIF:X 1MHZ
CALC:MASK:LOW:SHIF:Y 10
//Shifts the lower frequency mask by 1 MHz to the right and 10 dB up.
CALC:MASK:LOW:STAT ON
//Turns the lower frequency mask on.

//Defining the shape of an upper frequency mask
CALC:MASK:NAME 'AnotherMask'
//Creates or loads a frequency mask called 'AnotherMask'
CALC:MASK:MODE ABS
//Selects absolute power level values.
CALC:MASK:UPP -10MHZ,-10,-4MHZ,-10,-4MHZ,-20,4MHZ,-20,4MHZ,-10,10MHZ,-10
//Defines an upper frequency mask with 6 data points.
CALC:MASK:UPP:SHIF:X -1MHZ
CALC:MASK:UPP:SHIF 10
//Shift the upper frequency mask 1 MHz to the left and 10 dB up.
CALC:MASK:UPP:STAT ON
//Turns the upper frequency mask on.
//Alternatively, you can create an upper frequency mask automatically.
CALC:MASK:UPP:AUTO
//Automatically defines the shape of an upper frequency mask.

CALC:MASK:DEL
//Deletes the frequency mask called 'MyMask' in C:\FreqMasks.

```



Before making any changes to a frequency mask, you have to select one by name with `CALCulate<n>:MASK:NAME` on page 101.

Compared to manual configuration of frequency masks, any changes made to a frequency mask via remote control are saved after the corresponding command has been sent.

|   |     |
|---|-----|
| <code>CALCulate&lt;n&gt;:MASK:CDIRectory</code> .....         | 99  |
| <code>CALCulate&lt;n&gt;:MASK:COMMeNt</code> .....            | 99  |
| <code>CALCulate&lt;n&gt;:MASK:DELeTe</code> .....             | 99  |
| <code>CALCulate&lt;n&gt;:MASK:LOWer:SHIFt:X</code> .....      | 99  |
| <code>CALCulate&lt;n&gt;:MASK:LOWer:SHIFt:Y</code> .....      | 100 |
| <code>CALCulate&lt;n&gt;:MASK:LOWer[:STATe]</code> .....      | 100 |
| <code>CALCulate&lt;n&gt;:MASK:LOWer[:DATA]</code> .....       | 100 |
| <code>CALCulate&lt;n&gt;:MASK:MODE</code> .....               | 101 |
| <code>CALCulate&lt;n&gt;:MASK:NAME</code> .....               | 101 |
| <code>CALCulate&lt;n&gt;:MASK:SPAN</code> .....               | 101 |
| <code>CALCulate&lt;n&gt;:MASK:UPPer:AUTO</code> .....         | 101 |
| <code>CALCulate&lt;n&gt;:MASK:UPPer:SHIFt:X</code> .....      | 101 |
| <code>CALCulate&lt;n&gt;:MASK:UPPer:SHIFt:Y</code> .....      | 102 |
| <code>CALCulate&lt;n&gt;:MASK:UPPer[:STATe]</code> .....      | 102 |
| <code>CALCulate&lt;n&gt;:MASK:UPPer[:DATA]</code> .....       | 102 |
| <code>TRIGger&lt;n&gt;[:SEqueNce]:MASK:CONDition</code> ..... | 103 |

---

**CALCulate<n>:MASK:CDIRectory <Subdirectory>**

This command selects the directory the R&S ESR stores frequency masks in.

Note that the directory must exist already for the command to work.

**Parameters:**

<Subdirectory> String containing the path to the directory. The directory has to be a subdirectory of the default directory. Thus the path is always relative to the default directory (C:\R\_S\INSTR\FREQMASK). An empty string selects the default directory.

**Example:** See [chapter 6.3.5.2, "Using the Frequency Mask Trigger"](#), on page 97.

---

**CALCulate<n>:MASK:COMMeNt <Comment>**

This command defines a comment for the frequency mask that you have selected with [CALCulate<n>:MASK:NAME](#) on page 101.

**Parameters:**

<Comment> String containing the comment for the frequency mask.

**Example:** See [chapter 6.3.5.2, "Using the Frequency Mask Trigger"](#), on page 97.

---

**CALCulate<n>:MASK:DELeTe**

This command deletes the currently selected frequency mask.

Before making any changes to a frequency mask, you have to select one by name with [CALCulate<n>:MASK:NAME](#) on page 101.

**Example:** See [chapter 6.3.5.2, "Using the Frequency Mask Trigger"](#), on page 97.

**Usage:** Event

---

**CALCulate<n>:MASK:LOWer:SHIFt:X <Frequency>**

This command shifts the lower frequency mask horizontally by a specified distance. Positive values move the mask to the right, negative values shift the mask to the left.

Before making any changes to a frequency mask, you have to select one by name with [CALCulate<n>:MASK:NAME](#) on page 101.

**Parameters:**

<Frequency> Defines the distance of the shift.  
Default unit: Hz

**Example:** See [chapter 6.3.5.2, "Using the Frequency Mask Trigger"](#), on page 97.

**CALCulate<n>:MASK:LOWer:SHIFt:Y <Level>**

This command shifts the lower frequency mask vertically by a specified distance. Positive values move the mask upwards, negative values shift the mask downwards.

Before making any changes to a frequency mask, you have to select one by name with [CALCulate<n>:MASK:NAME](#) on page 101.

**Parameters:**

<Level> Defines the distance of the shift. The shift is relative to the current position.  
Default unit: dB

**Example:** See [chapter 6.3.5.2, "Using the Frequency Mask Trigger"](#), on page 97.

**CALCulate<n>:MASK:LOWer[:STATe] <State>**

This command turns the lower frequency mask on and off.

Before making any changes to a frequency mask, you have to select one by name with [CALCulate<n>:MASK:NAME](#) on page 101.

**Parameters:**

<State> **ON | OFF**

**Example:** See [chapter 6.3.5.2, "Using the Frequency Mask Trigger"](#), on page 97.

**CALCulate<n>:MASK:LOWer[:DATA] <Frequency>,<Level>,...**

This command defines the shape of the lower frequency mask.

Before making any changes to a frequency mask, you have to select one by name with [CALCulate<n>:MASK:NAME](#) on page 101.

The unit of the power levels depends on [CALCulate<n>:MASK:MODE](#) on page 101.

If you are using the command with the vector network analysis option (R&S FSV-K70), you can only use this command as a query.

**Parameters:**

<Frequency>,<Level> [N] pairs of numerical values. [N] is the number of data points the mask consists of.  
Each data point is defined by the frequency (in Hz) and the level (in dB or dBm). All values are separated by commas.  
Note that the data points have to be inside the current span.

**Example:** See [chapter 6.3.5.2, "Using the Frequency Mask Trigger"](#), on page 97.

---

**CALCulate<n>:MASK:MODE <Mode>**

This command defines the scaling of the level axis for frequency masks.

**Parameters:**

|        |  |
|--------|--|
| <Mode> | <b>ABSolute</b><br>absolute scaling of the level axis. |
|        | <b>RELative</b><br>relative scaling of the level axis. |
| *RST:  | RELative   |

---

**CALCulate<n>:MASK:NAME <Name>**

This command creates or selects a frequency mask with the name that you specify by the parameter. When you use it as a query, the command returns the name of the mask currently in use.

**Parameters:**

|        |  |
|--------|--|
| <Name> | String containing the name of the mask.<br>Note that an empty string does not select a frequency mask. |
|--------|--|

---

**CALCulate<n>:MASK:SPAN <Span>**

This command defines the frequency span of the frequency mask.

**Parameters:**

|        |                         |
|--------|-------------------------|
| <Span> | Range: 100 Hz to 40 MHz |
| *RST:  | 40 MHz                  |

**Example:**

CALC:MASK:SPAN 10 MHz  
Defines a span of 10 MHz.

---

**CALCulate<n>:MASK:UPPer:AUTO**

This command automatically defines the shape of an upper frequency mask according to the spectrum that is currently measured.

**Example:** See [chapter 6.3.5.2, "Using the Frequency Mask Trigger"](#), on page 97.

**Usage:** Event

---

**CALCulate<n>:MASK:UPPer:SHIFt:X <Frequency>**

This command shifts the lower frequency mask horizontally by a specified distance. Positive values move the mask to the right, negative values shift the mask to the left.

You have to select a mask before you can use this command with [CALCulate<n>:MASK:NAME](#) on page 101.

**Parameters:**

<Frequency> Defines the distance of the shift.

**Example:**

See [chapter 6.3.5.2, "Using the Frequency Mask Trigger"](#), on page 97.

**CALCulate<n>:MASK:UPPer:SHIFt:Y <Level>**

This command shifts the upper frequency mask vertically by a specified distance. Positive values move the mask upwards, negative values shift the mask downwards.

You have to select a mask before you can use this command with [CALCulate<n>:MASK:NAME](#) on page 101.

**Parameters:**

<Level> Defines the distance of the shift. The shift is relative to the current position.

Default unit: dB

**Example:**

See [chapter 6.3.5.2, "Using the Frequency Mask Trigger"](#), on page 97.

**CALCulate<n>:MASK:UPPer[:STATe] <State>**

This command turns the upper frequency mask on and off.

Before making any changes to a frequency mask, you have to select one by name with [CALCulate<n>:MASK:NAME](#) on page 101.

**Parameters:**

<State> **ON | OFF**

**Example:**

See [chapter 6.3.5.2, "Using the Frequency Mask Trigger"](#), on page 97.

**CALCulate<n>:MASK:UPPer[:DATA] <Frequency>,<Level>,...**

This command activates and defines the shape of the upper frequency mask trigger mask.

You have to select a mask before you can use this command with [CALCulate<n>:MASK:NAME](#) on page 101.

The unit of the power levels depends on [CALCulate<n>:MASK:MODE](#) on page 101.

If you are using the command with the vector network analysis option (R&S FSV-K70), you can only use this command as a query.

**Parameters:**

<Frequency>  
<Level>

[N] pairs of numerical values. [N] is the number of data points the mask consists of.

Each data point is defined by the frequency (in Hz) and the amplitude (in dB or dBm). All values are separated by commas. Note that the data points have to be inside the current span.

**Example:**

See [chapter 6.3.5.2, "Using the Frequency Mask Trigger"](#), on page 97.

**TRIGger**<n>[:SEQuence]:MASK:CONDition <Condition>

This command sets the condition that activates the frequency mask trigger.

**Parameters:**

<Condition>

**ENTer**

Triggers on entering the frequency mask.

**LEAVing**

Triggers on leaving the frequency mask.

**INSide**

The trigger is active as long as the signal is inside the frequency mask.

**OUTSide**

The trigger is active as long as the signal is outside the frequency mask.

\*RST:       INSide

**Example:**

See [chapter 6.3.5.2, "Using the Frequency Mask Trigger"](#), on page 97.

## 6.4 Analysis

- [Working with Traces](#).....103
- [Using Markers](#).....107

### 6.4.1 Working with Traces

|   |     |
|---|-----|
| <a href="#">DISPlay[:WINDow&lt;n&gt;]:TRACe&lt;t&gt;:MODE</a> .....             | 104 |
| <a href="#">DISPlay[:WINDow&lt;n&gt;]:TRACe&lt;t&gt;:MODE:HCONtinuous</a> ..... | 104 |
| <a href="#">DISPlay[:WINDow&lt;n&gt;]:TRACe&lt;t&gt;[:STATe]</a> .....          | 105 |
| <a href="#">FORMat[:DATA]</a> .....   | 105 |
| <a href="#">FORMat:DEXPort:DSEPARATOR</a> .....                                 | 106 |
| <a href="#">MMEMory:STORe&lt;n&gt;:TRACe</a> .....                              | 106 |
| <a href="#">[SENSe:][WINDow:]DETEctor&lt;trace&gt;[:FUNCTion]</a> .....         | 106 |
| <a href="#">TRACe&lt;n&gt;:COPY</a> .....                                       | 107 |
| <a href="#">TRACe&lt;n&gt;[:DATA]</a> .....                                     | 107 |

**DISPlay[:WINDow<n>]:TRACe<t>:MODE <Mode>**

This command defines the type of display and the evaluation of the traces. WRITE corresponds to the Clr/Write mode of manual operation. The trace is switched off (= BLANK in manual operation) with `DISPlay[:WINDow<n>]:TRACe<t>[:STATe]`.

**Suffix:**

<n> window; For applications that do not have more than 1 measurement window, the suffix <n> is irrelevant.

<t> trace

**Parameters:**

<Mode> For more information on trace modes see the documentation of the R&S ESR.

**BLANK**

Blank trace.

**MAXHold**

Maximum value trace.

**MINHold**

Minimum value trace.

**VIEW**

Frozen trace.

**WRITE**

Clear write trace mode.

**Example:**

```
INIT:CONT OFF
```

Switching to single sweep mode.

```
SWE:COUN 16
```

Sets the number of measurements to 16.

```
DISP:TRAC3:MODE MAXH
```

Switches on the calculation of the maximum peak for trace 3.

```
INIT;*WAI
```

Starts the measurement and waits for the end of the 16 sweeps.

**DISPlay[:WINDow<n>]:TRACe<t>:MODE:HCONTinuous <State>**

This command defines whether traces in Min Hold, Max Hold and Average mode (see `DISPlay[:WINDow<n>]:TRACe<t>:MODE` on page 104) are reset after a parameter is changed.

Normally, the measurement is started anew after parameter changes, before the measurement results are evaluated (e.g. using a marker). In all cases that require a new measurement after parameter changes, the trace is reset automatically to avoid false results (e.g. with span changes). For applications that require no reset after parameter changes, the automatic reset can be switched off.

**Suffix:**

<n> window; For applications that do not have more than 1 measurement window, the suffix <n> is irrelevant.



<t> trace

**Parameters:**

<State>

**ON**

The automatic reset is switched off.

**OFF**

After certain parameter changes the traces are reset.

\*RST: OFF

**Example:**

DISP:WIND:TRAC3:MODE:HCON ON  
Switches off the reset function.

**DISPlay[:WINDow<n>]:TRACe<t>[:STATe] <State>**

This command switches on or off the display of the corresponding trace. The other measurements are not aborted but continue running in the background.

**Suffix:**

<n>

window; For applications that do not have more than 1 measurement window, the suffix <n> is irrelevant.

<t>

trace

**Parameters:**

<State>

ON | OFF

\*RST: ON for TRACe1, OFF for TRACe2 to 6

**Example:**

DISP:TRAC3 ON

**FORMat[:DATA] <Format>**

This command selects the data format for the data transmitted from the R&S ESR to the controlling computer. It is used for the transmission of trace data. The data format of trace data received by the instrument is automatically recognized, regardless of the format which is programmed.

**Parameters:**

<Format>

**AScii**

ASCII data are transmitted in plain text, separated by commas.

**REAL**

REAL data are transmitted as 32-bit IEEE 754 floating-point numbers in the "definite length block format".

\*RST: ASCII

**Example:**

FORM REAL, 32  
FORM ASC

**FORMat:DEXPort:DSEParator** <Separator>

This command defines which decimal separator (decimal point or comma) is to be used for outputting measurement data to the file in ASCII format. Different languages of evaluation programs (e.g. MS-Excel) can thus be supported.

**Parameters:**

<Separator>            POINT | COMMA  
 \*RST:                (factory setting is POINT; \*RST does not affect setting)

**Example:**

FORM:DEXP:DSEP POIN  
 Sets the decimal point as separator.

**MMEMory:STORe<n>:TRACe** <Trace>, <FileName>

This command stores the selected trace in the specified window in a file with ASCII format. The file format is described in [chapter 3.6, "ASCII File Export Format"](#), on page 43

The decimal separator (decimal point or comma) for floating-point numerals contained in the file is defined with the `FORMat:DEXPort:DSEParator` command (see [FORMat:DEXPort:DSEParator](#) on page 106).

**Suffix:**

<n>                    window; For applications that do not have more than 1 measurement window, the suffix <n> is irrelevant.

**Parameters:**

<Trace>                selected measurement trace  
 <FileName>            DOS file name  
 The file name includes indication of the path and the drive name. Indication of the path complies with DOS conventions.

**Example:**

MMEM:STOR:TRAC 3, 'TEST.ASC'  
 Stores trace 3 in the file TEST.ASC.

**[SENSe:][WINDow:]DETector<trace>[:FUNction]** <Function>

This command selects the detector for the data acquisition in the selected trace.

**Suffix:**

<trace>                1...4  
 Selects the trace.

<trace>                1...6  
 trace

**Parameters:**

<Function>            NEGative | POSitive | SAMPlE | AVERAge  
 \*RST:                APEak

**Example:**

DET POS  
 Sets the detector to "positive peak".

---

**TRACe<n>:COPY** <TraceNumber>, <TraceNumber>

This command copies data from one trace to another.

**Suffix:**

<n> window; For applications that do not have more than 1 measurement window, the suffix <n> is irrelevant.

**Parameters:**

<TraceNumber>, TRACE1 | TRACE2 | TRACE3 | TRACE4 | TRACE5 | TRACE6,  
 <TraceNumber> TRACE1 | TRACE2 | TRACE3 | TRACE4 | TRACE5 | TRACE6  
 The first argument is the destination of the data to be copied, the second argument describes the source.

**Example:** TRAC: COPY TRACE1, TRACE2

---

**TRACe<n>[:DATA]** <ResultType>

This command queries the current trace data or measurement results.

The data format depends on [FORMat \[:DATA\]](#) on page 105.

**Parameters:**

<ResultType> Selects the type of result to be returned.

**TRACE1 | ... | TRACE6**

Returns the trace data for the corresponding trace.

**SPECTrogram | SGRam**

Returns the results of the spectrogram result display.  
 For every frame in the spectrogram, the command returns the power levels that have been measured, one for each sweep point. The number of frames depends on the size of the history depth. The power level depends on the unit you have currently set.

**PSPectrum**

Returns the results of the persistence spectrum result display. The command returns 801\*600 percentages, one for each pixel in the histogram

**HMAXhold**

Returns the results of the maxhold trace in the persistence spectrum result display. The command returns 801\*600 percentages, one for each pixel in the maxhold trace.

**Example:** TRAC? PSP  
 Returns the results of the persistence spectrum result display.

## 6.4.2 Using Markers

- [Configuring Markers and Delta Markers](#).....108
- [Positioning Markers](#).....116
- [Positioning Markers in the Spectrogram](#).....121

- Positioning Delta Markers.....127
- Positioning Delta Markers in the Spectrogram.....130
- Using the Marker Search.....136

#### 6.4.2.1 Configuring Markers and Delta Markers

|   |     |
|---|-----|
| CALCulate<n>:MARKer<m>:AOFF.....            | 108 |
| CALCulate<n>:MARKer<m>:FUNction:ZOOM.....   | 108 |
| CALCulate<n>:MARKer<m>:LOEXclude.....       | 109 |
| CALCulate<n>:MARKer<m>[:STATe].....         | 109 |
| CALCulate<n>:MARKer<m>:TRACe.....           | 109 |
| CALCulate<n>:MARKer<m>:X.....               | 110 |
| CALCulate<n>:MARKer<m>:X:SSIZe.....         | 110 |
| CALCulate<n>:MARKer<m>:Y.....               | 111 |
| CALCulate<n>:MARKer<m>:Z?.....              | 112 |
| CALCulate<n>:DELTAmarker<m>:LINK.....       | 112 |
| CALCulate<n>:DELTAmarker<m>:MODE.....       | 112 |
| CALCulate<n>:DELTAmarker<m>:MREF.....       | 113 |
| CALCulate<n>:DELTAmarker<m>[:STATe].....    | 113 |
| CALCulate<n>:DELTAmarker<m>:TRACe.....      | 113 |
| CALCulate<n>:DELTAmarker<m>:X.....          | 114 |
| CALCulate<n>:DELTAmarker<m>:X:RELAtive..... | 114 |
| CALCulate<n>:DELTAmarker<m>:Y.....          | 115 |
| CALCulate<n>:DELTAmarker<m>:Z?.....         | 115 |
| DISPlay:MTABLE.....                         | 115 |

---

#### CALCulate<n>:MARKer<m>:AOFF

This command all markers off, including delta markers and marker measurement functions.

##### Suffix:

|     |                                 |
|-----|---------------------------------|
| <n> | Selects the measurement window. |
| <m> | depends on mode<br>irrelevant   |

##### Example:

CALC:MARK:AOFF  
Switches off all markers.

##### Usage:

Event

---

#### CALCulate<n>:MARKer<m>:FUNction:ZOOM <Range>

This command defines the range to be zoomed around marker 1. Marker 1 is activated first, if necessary.

The marker frequency becomes the new receiver or center frequency and the span is adjusted according to the zoom factor.

Note that you should perform a complete measurement with synchronization to the end of the measurement. This is only possible for single sweeps.

**Suffix:**

<n> Selects the measurement window.

<m> Selects the marker.

**Parameters:**

<Range> <numeric\_value>

**Example:**

```
INIT:CONT OFF
Switches to single sweep mode
CALC:MARK:FUNC:ZOOM 1kHz; *WAI
Activates zooming and waits for its end.
```

**CALCulate<n>:MARKer<m>:LOEXclude <State>**

This command turns the local oscillator suppression during a peak search on or off.

**Suffix:**

<n> Selects the measurement window.

<m> irrelevant

**Parameters:**

<State> ON | OFF

\*RST: ON

**Example:**

```
CALC:MARK:LOEX ON
```

**CALCulate<n>:MARKer<m>[:STATe] <State>**

This command turns markers on and off.

If the corresponding marker number is currently active as a deltamarker, it is turned into a normal marker.

**Suffix:**

<n> Selects the measurement window.

<m> depends on mode  
Selects the marker.

**Parameters:**

<State> ON | OFF

\*RST: OFF

**Example:**

```
CALC:MARK3 ON
Switches on marker 3 or switches to marker mode.
```

**CALCulate<n>:MARKer<m>:TRACe <Trace>**

This command selects the trace a marker is positioned on.

The corresponding trace must have a trace mode other than "Blank".

If necessary, the corresponding marker is switched on prior to the assignment.

In the persistence spectrum result display, the command also defines if the marker is positioned on the persistence trace or the maxhold trace.

**Suffix:**

<n>                      Selects the measurement window.

<m>                      depends on mode  
Selects the marker.

**Parameters:**

<Trace>                **MAXHold**  
Defines the maxhold trace as the trace to put the delta marker on.  
This parameter is available only for the persistence spectrum result display.

**WRITE**  
Defines the persistence trace as the trace to put the delta marker on.  
This parameter is available only for the persistence spectrum result display.

**Example:**

`CALC:MARK3:TRAC 2`  
Assigns marker 3 to trace 2.

**CALCulate<n>:MARKer<m>:X <Position>**

This command positions a marker on a particular coordinate on the x-axis.

**Suffix:**

<n>                      Selects the measurement window.

<m>                      Selects the marker.

**Parameters:**

<Position>            Numeric value that defines the marker position on the x-axis. The unit is either Hz (frequency domain) or s (time domain) or dB (statistics).

Range:                The range depends on the current x-axis range.

**Example:**

`CALC:MARK2:X 1.7MHz`  
Positions marker 2 to frequency 1.7 MHz.

**CALCulate<n>:MARKer<m>:X:SSIZE <StepSize>**

This command defines the step size of the rotary knob for marker or delta marker value changes. It only takes effect in manual operation.

The marker step size is unavailable for statistical measurements.

**Suffix:**

<n>                      irrelevant

<m>                      irrelevant

**Parameters:**

&lt;StepSize&gt;

**STANDARD**

step size corresponds to space between two pixels

**POINTS**

step size corresponds to space between two measured values

\*RST: POINTs

**Example:**

CALC:MARK:X:SSIZ STAN

Sets the measured value step size.

**CALCulate<n>:MARKer<m>:Y <MarkerPosition>**

This command queries the measured value of a marker.

If necessary, the command activates the marker or turns a delta marker into a normal marker.

In the persistence spectrum result display of the realtime analyzer, it is also possible to set the marker with this command. You can select whether to query the results of the persistence trace or the maxhold trace with `CALCulate<n>:DELTAmarker<m>:TRACe` on page 113.

To get a valid result, you have to perform a complete measurement with synchronization to the end of the measurement before reading out the result. This is only possible for single sweeps.

The unit of results depends on the result display and the unit you have selected.

**Suffix:**

&lt;n&gt;

Selects the measurement window.

&lt;m&gt;

Selects the marker.

**Parameters:**

&lt;MarkerPosition&gt;

Defines the vertical marker position in the persistence spectrum result display.

**Return values:**

&lt;Result&gt;

The measured value of the selected marker is returned.

**Example:**

INIT:CONT OFF

Switches to single sweep mode.

CALC:MARK2 ON

Switches marker 2.

INIT;\*WAI

Starts a sweep and waits for the end.

CALC:MARK2:Y?

Outputs the measured value of marker 2.

In I/Q Analyzer mode, for "Real/Imag (I/Q)", for example:

1.852719887E-011,0

**CALCulate<n>:MARKer<m>:Z?**

This command queries the z-axis value of the indicated marker in the persistence spectrum result display.

You can select whether to query the results of the persistence trace or the maxhold trace with `CALCulate<n>:DELTamarker<m>:TRACe` on page 113.

**Return values:**

<percentage>            The return value is the percentage of hits on the marker position.

**Usage:**                    Query only

**Mode:**                     RT

**CALCulate<n>:DELTamarker<m>:LINK <State>**

This command links delta marker 1 to marker 1.

If you change the horizontal position of the marker, so does the delta marker.

**Suffix:**

<n>                            Selects the measurement window.

<m>                            1  
irrelevant

**Parameters:**

<State>                    ON | OFF  
\*RST:                    OFF

**Example:**                `CALC:DELT:LINK ON`

**CALCulate<n>:DELTamarker<m>:MODE <Mode>**

This command selects the delta marker mode.

**Suffix:**

<n>                            Selects the measurement window.

<m>                            Selects the marker.

**Parameters:**

<Mode>                    **ABSolute**  
Delta marker position in absolute terms.  
**RELative**  
Delta marker position in relation to a reference marker.  
\*RST:                    REL

**Example:**                `CALC:DELT:MODE ABS`  
Absolute delta marker position.



**CALCulate<n>:DELTamarker<m>:MREF <RefMarkerNo>**

This command defines the reference marker for a delta marker other than marker 1.

The reference may be another marker or the fixed reference.

**Suffix:**

<n> Selects the measurement window.

<m> Selects the marker.

**Parameters:**

<RefMarkerNo> **1 ... 16**  
Selects markers 1 to 16 as the reference.

**FIXed**

Selects the fixed reference as the reference.

**Example:**

`CALC:DELT3:MREF 2`

Specifies that the values of delta marker 3 are relative to marker 2.

**CALCulate<n>:DELTamarker<m>[:STATE] <State>**

This command turns delta markers on and off.

If the corresponding marker was a normal marker, it is turned into a delta marker.

No suffix at DELTmarker turns on delta marker 1.

**Suffix:**

<n> Selects the measurement window.

<m> Selects the marker.

**Parameters:**

<State> ON | OFF  
\*RST: OFF

**Example:**

`CALC:DELT1 ON`

Switches marker 1 to delta marker mode.

**CALCulate<n>:DELTamarker<m>:TRACe <TraceNumber>**

This command selects the trace a delta marker is positioned on.

The corresponding trace must have a trace mode other than "Blank".

In the persistence spectrum result display, the command also defines if the delta marker is positioned on the persistence trace or the maxhold trace.

**Suffix:**

<n> Selects the measurement window.

<m> Selects the marker.

**Parameters:**

&lt;TraceNumber&gt;

**1 ... 6**

Trace number the marker is positioned on.

**MAXHold**

Defines the maxhold trace as the trace to put the delta marker on. This parameter is available only for the persistence spectrum result display.

**WRITE**

Defines the persistence trace as the trace to put the delta marker on. This parameter is available only for the persistence spectrum result display.

**Example:**`CALC:DELT3:TRAC 2`

Assigns delta marker 3 to trace 2.

**CALCulate<n>:DELTamarker<m>:X <Position>**

This command positions a delta marker on a particular coordinate on the x-axis.

The position is an absolute value.

**Suffix:**

&lt;n&gt;

Selects the measurement window.

&lt;m&gt;

Selects the marker.

**Parameters:**

&lt;Position&gt;

0 to maximum frequency or sweep time

**Example:**`CALC:DELT:X?`

Outputs the absolute frequency/time of delta marker 1.

**CALCulate<n>:DELTamarker<m>:X:RELative**

This command queries the x-value of the selected delta marker relative to marker 1 or to the reference position (for `CALC:DELT:FUNC:FIX:STAT ON`). The command activates the corresponding delta marker, if necessary.

**Suffix:**

&lt;n&gt;

Selects the measurement window.

&lt;m&gt;

Selects the marker.

**Example:**`CALC:DELT3:X:REL?`

Outputs the frequency of delta marker 3 relative to marker 1 or relative to the reference position.

**CALCulate<n>:DELTamarker<m>:Y**

This command queries the measured value of a delta marker. The corresponding delta marker is activated, if necessary. The output is always a relative value referred to marker 1 or to the reference position (reference fixed active).

In the persistence spectrum result display of the realtime analyzer, it is also possible to set the delta marker with this command. You can either set the delta marker on an absolute position or a position relative to the marker, depending on the marker mode ([CALCulate<n>:DELTamarker<m>:MODE](#) on page 112). The query, however, always returns the relative position. You can select whether to query the results of the persistence trace or the maxhold trace with [CALCulate<n>:DELTamarker<m>:TRACe](#) on page 113.

To get a valid result, you have to perform a complete measurement with synchronization to the end of the measurement before reading out the result. This is only possible for single sweeps.

The unit of results depends on the result display and the unit you have selected.

**Suffix:**

<n>                      Selects the measurement window.  
 <m>                      Selects the marker.

**Example:**

```
INIT:CONT OFF
Switches to single sweep mode.
INIT;*WAI
Starts a sweep and waits for its end.
CALC:DELT2 ON
Switches on delta marker 2.
CALC:DELT2:Y?
Outputs measurement value of delta marker 2.
```

**CALCulate<n>:DELTamarker<m>:Z?**

This command queries the z-axis value of the indicated delta marker in the persistence spectrum result display.

You can select whether to query the results of the persistence trace or the maxhold trace with [CALCulate<n>:DELTamarker<m>:TRACe](#) on page 113.

**Return values:**

<percentage>            The return value is the percentage of hits on the marker position.

**Usage:**                      Query only

**Mode:**                        RT

**DISPlay:MTABLE <DisplayMode>**

This command turns the marker table on and off.

**Parameters:**

&lt;DisplayMode&gt;

**ON**

Marker table is displayed.

**OFF**

Marker table is not displayed.

**AUTO**

Marker table is only displayed if 2 or more markers are active.

\*RST: AUTO

**Example:**

To activate the table display:

DISP:MTAB ON

To query the current state of the marker table display:

DISP:MTAB?

**6.4.2.2 Positioning Markers**

|  |     |
|--|-----|
| CALCulate<n>:MARKer<m>:FUNction:CENTer.....    | 116 |
| CALCulate<n>:MARKer<m>:FUNction:REFerence..... | 116 |
| CALCulate<n>:MARKer<m>:MAXimum:AUTO.....       | 117 |
| CALCulate<n>:MARKer<m>:MAXimum:LEFT.....       | 117 |
| CALCulate<n>:MARKer<m>:MAXimum:NEXT.....       | 118 |
| CALCulate<n>:MARKer<m>:MAXimum[:PEAK].....     | 118 |
| CALCulate<n>:MARKer<m>:MAXimum:RIGHT.....      | 118 |
| CALCulate<n>:MARKer<m>:MINimum:AUTO.....       | 119 |
| CALCulate<n>:MARKer<m>:MINimum:LEFT.....       | 119 |
| CALCulate<n>:MARKer<m>:MINimum:NEXT.....       | 120 |
| CALCulate<n>:MARKer<m>:MINimum[:PEAK].....     | 120 |
| CALCulate<n>:MARKer<m>:MINimum:RIGHT.....      | 121 |

**CALCulate<n>:MARKer<m>:FUNction:CENTer**

This command matches the center or receiver frequency to the frequency of a marker.

If you use the command in combination with a delta marker, that delta marker is turned into a normal marker.

**Suffix:**

&lt;n&gt; Selects the measurement window.

&lt;m&gt; Selects the marker.

**Example:**

CALC:MARK2:FUNC:CENT

Sets the center frequency to the frequency of marker 2.

**CALCulate<n>:MARKer<m>:FUNction:REFerence**

This command sets the reference level to the power measured by a marker.

If you use the command in combination with a delta marker, that delta marker is turned into a normal marker.

**Suffix:**

<n> Selects the measurement window.

<m> Selects the marker.

**Example:**

```
CALC:MARK2:FUNC:REF
```

Sets the reference level to the level of marker 2.

**CALCulate<n>:MARKer<m>:MAXimum:AUTO <State>**

This command turns an automatic marker peak search for a trace maximum on and off. The command performs the peak search after each sweep.

An automatic peak search may be used during adjustments of a device under test to keep track of the actual peak marker position and level.

If no maximum value is found on the trace (level spacing to adjacent values < peak excursion), an execution error (error code: -200) is produced.

**Suffix:**

<n> Selects the measurement window.

<m> Selects the marker.

**Parameters:**

<State> ON | OFF

\*RST: OFF

**Example:**

```
CALC:MARK:MAX:AUTO ON
```

Activates the automatic peak search function for marker 1 at the end of each particular sweep.

**Usage:**

Event

**CALCulate<n>:MARKer<m>:MAXimum:LEFT**

This command positions a marker to the next smaller trace maximum on the left of the current position (i.e. in descending X values).

If no next smaller maximum value is found on the trace (level spacing to adjacent values < peak excursion), an execution error (error code: -200) is produced.

In "Spectrogram" mode, this command positions the specified marker on the next peak level of the x-axis. The search includes only the data to the left of the current marker position in the current frame. It does not change the position of the marker on the y-axis.

**Suffix:**

<n> Selects the measurement window.

<m> Selects the marker.

**Example:**

```
CALC:MARK2:MAX:LEFT
```

Positions marker 2 to the next lower maximum value to the left of the current value.

**Usage:**

Event

**CALCulate<n>:MARKer<m>:MAXimum:NEXT**

This command positions the marker to the next smaller trace maximum.

If no next smaller maximum value is found on the trace (level spacing to adjacent values < peak excursion), an execution error (error code: -200) is produced.

In "Spectrogram" mode, this command positions the specified marker on the next peak level of the x-axis. The search includes only the data to the left of the current marker position in the current frame. It does not change the position of the marker on the y-axis.

**Suffix:**

<n>                      Selects the measurement window.

<m>                      Selects the marker.

**Example:**

`CALC:MARK2:MAX:NEXT`

Positions marker 2 to the next lower maximum value.

**Usage:**

Event

**CALCulate<n>:MARKer<m>:MAXimum[:PEAK]**

This command positions the marker on the current trace maximum.

The corresponding marker is activated first or switched to the marker mode.

If no maximum value is found on the trace (level spacing to adjacent values < peak excursion), an execution error (error code: -200) is produced.

In "Spectrogram" mode, this command positions the specified marker on the next peak level of the x-axis. The search includes only the data to the left of the current marker position in the current frame. It does not change the position of the marker on the y-axis.

**Suffix:**

<n>                      Selects the measurement window.

<m>                      depends on mode  
Selects the marker.

**Example:**

`CALC:MARK2:MAX`

Positions marker 2 to the maximum value of the trace.

**Usage:**

Event

**CALCulate<n>:MARKer<m>:MAXimum:RIGHT**

This command positions a marker to the next smaller trace maximum on the right of the current value (i.e. in ascending X values).

If no next smaller maximum value is found on the trace (level spacing to adjacent values < peak excursion), an execution error (error code: -200) is produced.

In "Spectrogram" mode, this command positions the specified marker on the next peak level of the x-axis. The search includes only the data to the left of the current marker position in the current frame. It does not change the position of the marker on the y-axis.

**Suffix:**  
 <n> Selects the measurement window.  
 <m> Selects the marker.

**Example:** `CALC:MARK2:MAX:RIGH`  
 Positions marker 2 to the next lower maximum value to the right of the current value.

**Usage:** Event

#### **CALCulate<n>:MARKer<m>:MINimum:AUTO <State>**

This command turns an automatic marker peak search for a trace maximum on and off. The command performs the peak search after each sweep.

An automatic peak search may be used during adjustments of a device under test to keep track of the actual peak marker position and level.

If no maximum value is found on the trace (level spacing to adjacent values < peak excursion), an execution error (error code: -200) is produced.

**Suffix:**  
 <n> Selects the measurement window.  
 <m> Selects the marker.

**Parameters:**  
 <State> ON | OFF  
 \*RST: OFF

**Example:** `CALC:MARK:MIN:AUTO ON`  
 Activates the automatic minimum value search function for marker 1 at the end of each particular sweep.

#### **CALCulate<n>:MARKer<m>:MINimum:LEFT**

This command positions a marker to the next higher trace minimum on the left of the current value (i.e. in descending X direction).

If no next higher minimum value is found on the trace (level spacing to adjacent values < peak excursion), an execution error (error code: -200) is produced.

In "Spectrogram" mode, this command positions the specified marker on the next peak level of the x-axis. The search includes only the data to the left of the current marker position in the current frame. It does not change the position of the marker on the y-axis.

**Suffix:**  
 <n> Selects the measurement window.  
 <m> Selects the marker.

**Example:**            `CALC:MARK2:MIN`  
 Positions marker 2 to the minimum value of the trace.  
`CALC:MARK2:MIN:LEFT`  
 Positions marker 2 to the next higher minimum value to the left of the current value.

**Usage:**            Event

#### **CALCulate<n>:MARKer<m>:MINimum:NEXT**

This command positions the marker to the next higher trace minimum.

If no next higher minimum value is found on the trace (level spacing to adjacent values < peak excursion), an execution error (error code: -200) is produced.

In "Spectrogram" mode, this command positions the specified marker on the next peak level of the x-axis. The search includes only the data to the left of the current marker position in the current frame. It does not change the position of the marker on the y-axis.

**Suffix:**

<n>                    Selects the measurement window.

<m>                    Selects the marker.

**Example:**            `CALC:MARK2:MIN`  
 Positions marker 2 to the minimum value of the trace.  
`CALC:MARK2:MIN:NEXT`  
 Positions marker 2 to the next higher maximum value.

**Usage:**            Event

#### **CALCulate<n>:MARKer<m>:MINimum[:PEAK]**

This command positions the marker on the current trace minimum.

The corresponding marker is activated first or switched to marker mode, if necessary.

If no minimum value is found on the trace (level spacing to adjacent values < peak excursion), an execution error (error code: -200) is produced.

In "Spectrogram" mode, this command positions the specified marker on the next peak level of the x-axis. The search includes only the data to the left of the current marker position in the current frame. It does not change the position of the marker on the y-axis.

**Suffix:**

<n>                    Selects the measurement window.

<m>                    depends on mode  
 Selects the marker.

**Example:**            `CALC:MARK2:MIN`  
 Positions marker 2 to the minimum value of the trace.

**Usage:**            Event



**CALCulate<n>:MARKer<m>:MINimum:RIGHT**

This command positions a marker to the next higher trace minimum on the right of the current value (i.e. in ascending X direction).

If no next higher minimum value is found on the trace (level spacing to adjacent values < peak excursion), an execution error (error code: -200) is produced.

In "Spectrogram" mode, this command positions the specified marker on the next peak level of the x-axis. The search includes only the data to the left of the current marker position in the current frame. It does not change the position of the marker on the y-axis.

**Suffix:**

<n> Selects the measurement window.

<m> Selects the marker.

**Example:**

`CALC:MARK2:MIN`

Positions marker 2 to the minimum value of the trace.

`CALC:MARK2:MIN:RIGHT`

Positions marker 2 to the next higher minimum value to the right of the current value.

**Usage:** Event

**6.4.2.3 Positioning Markers in the Spectrogram**

In addition to the commands mentioned in [chapter 6.4.2.2, "Positioning Markers"](#), on page 116, the spectrogram also supports the commands described below.

|   |     |
|---|-----|
| <code>CALCulate&lt;n&gt;:MARKer&lt;m&gt;:SGRam:FRAME</code> .....             | 121 |
| <code>CALCulate&lt;n&gt;:MARKer&lt;m&gt;:SGRam:SARea</code> .....             | 122 |
| <code>CALCulate&lt;n&gt;:MARKer&lt;m&gt;:SGRam:XY:MAXimum[:PEAK]</code> ..... | 122 |
| <code>CALCulate&lt;n&gt;:MARKer&lt;m&gt;:SGRam:XY:MINimum[:PEAK]</code> ..... | 123 |
| <code>CALCulate&lt;n&gt;:MARKer&lt;m&gt;:SGRam:Y:MAXimum:ABOVE</code> .....   | 123 |
| <code>CALCulate&lt;n&gt;:MARKer&lt;m&gt;:SGRam:Y:MAXimum:BELOW</code> .....   | 124 |
| <code>CALCulate&lt;n&gt;:MARKer&lt;m&gt;:SGRam:Y:MAXimum:NEXT</code> .....    | 124 |
| <code>CALCulate&lt;n&gt;:MARKer&lt;m&gt;:SGRam:Y:MAXimum[:PEAK]</code> .....  | 125 |
| <code>CALCulate&lt;n&gt;:MARKer&lt;m&gt;:SGRam:Y:MINimum:ABOVE</code> .....   | 125 |
| <code>CALCulate&lt;n&gt;:MARKer&lt;m&gt;:SGRam:Y:MINimum:BELOW</code> .....   | 125 |
| <code>CALCulate&lt;n&gt;:MARKer&lt;m&gt;:SGRam:Y:MINimum:NEXT</code> .....    | 126 |
| <code>CALCulate&lt;n&gt;:MARKer&lt;m&gt;:SGRam:Y:MINimum[:PEAK]</code> .....  | 126 |
| <code>CALCulate&lt;n&gt;:MARKer&lt;m&gt;:SGRam:Y:TRIGger</code> .....         | 127 |

**CALCulate<n>:MARKer<m>:SGRam:FRAME <Frame> | <Time>**

This command positions the marker on a particular frame.

The command is available for the spectrogram.

**Suffix:**

<n> 1...4  
Selects the measurement window.

<m> 1...16  
Selects the marker.

**Parameters:**

<Frame> | <Time> **<Frame> (if time stamp is off)**  
Defines the frame to place the marker on. The range is {0...number of recorded frames-1}

**<time> (if time stamp is on)**  
Defines the distance of the marker in seconds to the last measured frame (frame 0).

**Example:**

```
CALC:MARK:SGR:FRAM -20
```

Sets the marker on the 20th frame before the present.

```
CALC:MARK2:SGR:FRAM 2 s
```

Sets second marker on the frame 2 seconds ago.

**CALCulate<n>:MARKer<m>:SGRam:SARea <SearchArea>**

This command defines the marker search area.

The command is available for the spectrogram.

**Suffix:**

<n> 1...4  
Selects the measurement window.

<m> 1...16  
Selects the marker.

**Parameters:**

<SearchArea> **VISible**  
Performs a search in the visible frames.  
Note that VISible is ignored if Spectrogram is not visible for any reason (e.g. if the Spectrum Analyzer is in full screen mode or display update is inactive).

**MEMory**

Performs a search over all frames in the memory.

```
*RST: VISible
```

**Example:**

```
CALC:DELT:SGR:SAR MEM
```

Performs a search over all frames in the memory.

**CALCulate<n>:MARKer<m>:SGRam:XY:MAXimum[:PEAK]**

This command positions the specified marker on the current peak level of the spectrogram. The possible position depends on the marker search area.

The command is available for the spectrogram.

For more information, see [CALCulate<n>:MARKer<m>:SGRam:SARea](#) on page 122.

|                 |  |
|-----------------|--|
| <b>Suffix:</b>  |  |
| <n>             | 1...4<br>Selects the measurement window.   |
| <m>             | 1...16<br>Selects the marker.  |
| <b>Example:</b> | <pre>CALC:MARK2:SGR:SAR VIS</pre> <pre>CALC:MARK2:SGR:XY:MAX</pre> <p>Activates and positions marker 2 on the peak level in the visible Spectrogram.</p> |
| <b>Usage:</b>   | Event  |

---

### **CALCulate<n>:MARKer<m>:SGRam:XY:MINimum[:PEAK]**

This command positions the specified marker on the current minimum level of the spectrogram. The possible position depends on the marker search area.

The command is available for the spectrogram.

For more information, see [CALCulate<n>:MARKer<m>:SGRam:SARea](#) on page 122 .

<b>Suffix:</b>	
<n>	1...4 Selects the measurement window.
<m>	1...16 Selects the marker.
<b>Example:</b>	<pre>CALC:MARK3:SGR:SAR VIS</pre> <pre>CALC:MARK3:SGR:XY:MIN</pre> <p>Activates and positions marker 3 on the minimum level in the visible Spectrogram.</p>
<b>Usage:</b>	Event

---

### **CALCulate<n>:MARKer<m>:SGRam:Y:MAXimum:ABOVE**

This command positions the specified marker on the next peak level of the vertical axis. The search includes only frames above the current marker position. It does not change the horizontal position of the marker.

The command is available for the spectrogram.

<b>Suffix:</b>	
<n>	1...4 Selects the measurement window.
<m>	1...16 Selects the marker.

**Example:** `CALC:MARK2:SGR:Y:MAX`  
 Activates and positions marker 2 on the peak level of the y-axis.  
`CALC:MARK2:SGR:Y:MAX:ABV`  
 Positions marker 2 on the next higher level found in the diagram area above the current marker position.

**Usage:** Event

#### **CALCulate<n>:MARKer<m>:SGRam:Y:MAXimum:BELOW**

This command positions the specified marker on the next peak level of the vertical axis. The search includes only frames below the current marker position. It does not change the horizontal position of the marker.

The command is available for the spectrogram.

**Suffix:**

<n> 1...4  
 Selects the measurement window.

<m> 1...16  
 Selects the marker.

**Example:** `CALC:MARK2:SGR:Y:MAX`  
 Activates and positions marker 2 on the peak level of the y-axis.  
`CALC:MARK2:SGR:Y:MAX:BEL`  
 Positions marker 2 on the next higher level found in the diagram area below the current marker position.

**Usage:** Event

#### **CALCulate<n>:MARKer<m>:SGRam:Y:MAXimum:NEXT**

This command positions the specified marker on the next peak level of the vertical axis. The search includes frames above and below the current marker position. It does not change the horizontal position of the marker.

The command is available for the spectrogram.

**Suffix:**

<n> 1...4  
 Selects the measurement window.

<m> 1...16  
 Selects the marker.

**Example:** `CALC:MARK2:SGR:Y:MAX`  
 Activates and positions marker 2 on the peak level of the y-axis.  
`CALC:MARK2:SGR:Y:MAX:NEXT`  
 Positions marker 2 on the next higher level.

**Usage:** Event

**CALCulate<n>:MARKer<m>:SGRam:Y:MAXimum[:PEAK]**

This command positions the specified marker on the current peak level of the vertical axis. The search is performed over all frames. It does not change the horizontal position of the marker.

The command is available for the spectrogram.

**Suffix:**

<n> 1...4  
Selects the measurement window.

<m> 1...16  
Selects the marker.

**Example:** `CALC:MARK2:SGR:Y:MAX`  
Activates and positions marker 2 on the peak level of the y-axis.

**Usage:** Event

**CALCulate<n>:MARKer<m>:SGRam:Y:MINimum:ABOVE**

This command positions the specified marker on the next minimum level of the vertical axis. The search includes only frames above the current marker position. It does not change the horizontal position of the marker.

The command is available for the spectrogram.

**Suffix:**

<n> 1...4  
Selects the measurement window.

<m> 1...16  
Selects the marker.

**Example:** `CALC:MARK2:SGR:Y:MIN`  
Activates and positions marker 2 on the minimum level of the y-axis.  
`CALC:MARK2:SGR:Y:MIN:ABOV`  
Positions marker 2 on the next minimum level found in the diagram area above the current marker position.

**Usage:** Event

**CALCulate<n>:MARKer<m>:SGRam:Y:MINimum:BELOW**

This command positions the specified marker on the next minimum level of the vertical axis. The search includes only frames below the current marker position. It does not change the horizontal position of the marker.

The command is available for the spectrogram.

**Suffix:**

<n> 1...4  
Selects the measurement window.

<m> 1...16  
Selects the marker.

**Example:** `CALC:MARK2:SGR:Y:MIN`  
Activates and positions marker 2 on the minimum level of the y-axis.  
`CALC:MARK2:SGR:Y:MAX:BEL`  
Positions marker 2 on the next minimum level found in the diagram area below the current marker position.

**Usage:** Event

#### **CALCulate<n>:MARKer<m>:SGRam:Y:MINimum:NEXT**

This command positions the specified marker on the next minimum level of the vertical axis. The search includes frames above and below the current marker position. It does not change the horizontal position of the marker.

The command is available for the spectrogram.

**Suffix:**

<n> 1...4  
Selects the measurement window.

<m> 1...16  
Selects the marker.

**Example:** `CALC:MARK2:SGR:Y:MIN`  
Activates and positions marker 2 on the minimum level of the y-axis.  
`CALC:MARK2:SGR:Y:MIN:NEXT`  
Positions marker 2 on the next minimum level.

**Usage:** Event

#### **CALCulate<n>:MARKer<m>:SGRam:Y:MINimum[:PEAK]**

This command positions the specified marker on the current minimum level of the vertical axis. The search is performed over all captured frames. It does not change the horizontal position of the delta marker.

The command is available for the spectrogram.

**Suffix:**

<n> 1...4  
Selects the measurement window.

<m> 1...16  
Selects the marker.

**Example:** `CALC:MARK2:SGR:Y:MIN`  
Activates and positions marker 2 on the minimum level of the y-axis.

**Usage:** Event

**CALCulate<n>:MARKer<m>:SGRam:Y:TRIGger**

This command positions a marker in the spectrogram on the most recent trigger event.

**Suffix:**

<n> 1...4  
Selects the measurement window.

**Usage:** Event

**6.4.2.4 Positioning Delta Markers**

CALCulate<n>:DELTamarker<m>:MAXimum:LEFT.....	127
CALCulate<n>:DELTamarker<m>:MAXimum:NEXT.....	127
CALCulate<n>:DELTamarker<m>:MAXimum[:PEAK].....	128
CALCulate<n>:DELTamarker<m>:MAXimum:RIGHT.....	128
CALCulate<n>:DELTamarker<m>:MINimum:LEFT.....	129
CALCulate<n>:DELTamarker<m>:MINimum:NEXT.....	129
CALCulate<n>:DELTamarker<m>:MINimum[:PEAK].....	129
CALCulate<n>:DELTamarker<m>:MINimum:RIGHT.....	130

**CALCulate<n>:DELTamarker<m>:MAXimum:LEFT**

This command positions the delta marker to the next smaller trace maximum on the left of the current value (i.e. descending X values). The corresponding delta marker is activated first, if necessary.

If no next higher minimum value is found on the trace (level spacing to adjacent values < peak excursion), an execution error (error code: -200) is produced.

In "Spectrogram" mode, this command positions the specified delta marker on the next peak level of the x-axis. The search includes only the data to the left of the current marker position in the current frame. It does not change the position of the deltamarker on the y-axis.

**Suffix:**

<n> Selects the measurement window.  
<m> Selects the marker.

**Example:**

`CALC:DELT:MAX:LEFT`

Sets delta marker 1 to the next smaller maximum value to the left of the current value.

**CALCulate<n>:DELTamarker<m>:MAXimum:NEXT**

This command positions the delta marker to the next smaller trace maximum. The corresponding delta marker is activated first, if necessary.

If no next higher minimum value is found on the trace (level spacing to adjacent values < peak excursion), an execution error (error code: -200) is produced.

In "Spectrogram" mode, this command positions the specified delta marker on the next peak level of the x-axis. The search includes only the data to the left of the current marker position in the current frame. It does not change the position of the deltamarker on the y-axis.

**Suffix:**

<n> Selects the measurement window.

<m> Selects the marker.

**Example:**

`CALC:DELT2:MAX:NEXT`

Sets delta marker 2 to the next smaller maximum value.

**CALCulate<n>:DELTamarker<m>:MAXimum[:PEAK]**

This command positions the delta marker to the current trace maximum. If necessary, the corresponding delta marker is activated first.

In "Spectrogram" mode, this command positions the specified delta marker on the next peak level of the x-axis. The search includes only the data to the left of the current marker position in the current frame. It does not change the position of the deltamarker on the y-axis.

**Suffix:**

<n> Selects the measurement window.

<m> Selects the marker.

**Example:**

`CALC:DELT3:MAX`

Sets delta marker 3 to the maximum value of the associated trace.

**CALCulate<n>:DELTamarker<m>:MAXimum:RIGHT**

This command positions the delta marker to the next smaller trace maximum on the right of the current value (i.e. ascending X values). The corresponding delta marker is activated first, if necessary.

If no next higher minimum value is found on the trace (level spacing to adjacent values < peak excursion), an execution error (error code: -200) is produced.

In "Spectrogram" mode, this command positions the specified delta marker on the next peak level of the x-axis. The search includes only the data to the left of the current marker position in the current frame. It does not change the position of the deltamarker on the y-axis.

**Suffix:**

<n> Selects the measurement window.

<m> Selects the marker.

**Example:**

`CALC:DELT:MAX:RIGH`

Sets delta marker 1 to the next smaller maximum value to the right of the current value.



**CALCulate<n>:DELTamarker<m>:MINimum:LEFT**

This command positions the delta marker to the next higher trace minimum on the left of the current value (i.e. descending X values). The corresponding delta marker is activated first, if necessary.

If no next higher minimum value is found on the trace (level spacing to adjacent values < peak excursion), an execution error (error code: -200) is produced.

In "Spectrogram" mode, this command positions the specified delta marker on the next peak level of the x-axis. The search includes only the data to the left of the current marker position in the current frame. It does not change the position of the deltamarker on the y-axis.

**Suffix:**

<n> Selects the measurement window.

<m> Selects the marker.

**Example:**

`CALC:DELT:MIN:LEFT`

Sets delta marker 1 to the next higher minimum to the left of the current value.

**CALCulate<n>:DELTamarker<m>:MINimum:NEXT**

This command positions the delta marker to the next higher trace minimum. The corresponding delta marker is activated first, if necessary.

If no next higher minimum value is found on the trace (level spacing to adjacent values < peak excursion), an execution error (error code: -200) is produced.

In "Spectrogram" mode, this command positions the specified delta marker on the next peak level of the x-axis. The search includes only the data to the left of the current marker position in the current frame. It does not change the position of the deltamarker on the y-axis.

**Suffix:**

<n> Selects the measurement window.

<m> Selects the marker.

**Example:**

`CALC:DELT2:MIN:NEXT`

Sets delta marker 2 to the next higher minimum value.

**CALCulate<n>:DELTamarker<m>:MINimum[:PEAK]**

This command positions the delta marker to the current trace minimum. The corresponding delta marker is activated first, if necessary.

In "Spectrogram" mode, this command positions the specified delta marker on the next peak level of the x-axis. The search includes only the data to the left of the current marker position in the current frame. It does not change the position of the deltamarker on the y-axis.

<b>Suffix:</b>	
<n>	Selects the measurement window.
<m>	Selects the marker.
<b>Example:</b>	<code>CALC:DELT3:MIN</code> Sets delta marker 3 to the minimum value of the associated trace.

---

#### **CALCulate<n>:DELTamarker<m>:MINimum:RIGHT**

This command positions the delta marker to the next higher trace minimum on the right of the current value (i.e. ascending X values). The corresponding delta marker is activated first, if necessary.

If no next higher minimum value is found on the trace (level spacing to adjacent values < peak excursion), an execution error (error code: -200) is produced.

In "Spectrogram" mode, this command positions the specified delta marker on the next peak level of the x-axis. The search includes only the data to the left of the current marker position in the current frame. It does not change the position of the deltamarker on the y-axis.

<b>Suffix:</b>	
<n>	Selects the measurement window.
<m>	Selects the marker.
<b>Example:</b>	<code>CALC:DELT:MIN:RIGHT</code> Sets delta marker 1 to the next higher minimum value to the right of the current value.

#### **6.4.2.5 Positioning Delta Markers in the Spectrogram**

In addition to the commands mentioned in [chapter 6.4.2.4, "Positioning Delta Markers"](#), on page 127, the spectrogram also supports the commands described below.

<code>CALCulate&lt;n&gt;:DELTamarker&lt;m&gt;:SGRam:FRAMe</code> .....	131
<code>CALCulate&lt;n&gt;:DELTamarker&lt;m&gt;:SGRam:SARea</code> .....	131
<code>CALCulate&lt;n&gt;:DELTamarker&lt;m&gt;:SGRam:XY:MAXimum[:PEAK]</code> .....	132
<code>CALCulate&lt;n&gt;:DELTamarker&lt;m&gt;:SGRam:XY:MINimum[:PEAK]</code> .....	132
<code>CALCulate&lt;n&gt;:DELTamarker&lt;m&gt;:SGRam:Y:MAXimum:ABOVe</code> .....	132
<code>CALCulate&lt;n&gt;:DELTamarker&lt;m&gt;:SGRam:Y:MAXimum:BELow</code> .....	133
<code>CALCulate&lt;n&gt;:DELTamarker&lt;m&gt;:SGRam:Y:MAXimum:NEXT</code> .....	133
<code>CALCulate&lt;n&gt;:DELTamarker&lt;m&gt;:SGRam:Y:MAXimum[:PEAK]</code> .....	134
<code>CALCulate&lt;n&gt;:DELTamarker&lt;m&gt;:SGRam:Y:MINimum:ABOVe</code> .....	134
<code>CALCulate&lt;n&gt;:DELTamarker&lt;m&gt;:SGRam:Y:MINimum:BELow</code> .....	135
<code>CALCulate&lt;n&gt;:DELTamarker&lt;m&gt;:SGRam:Y:MINimum:NEXT</code> .....	135
<code>CALCulate&lt;n&gt;:DELTamarker&lt;m&gt;:SGRam:Y:MINimum[:PEAK]</code> .....	135
<code>CALCulate&lt;n&gt;:DELTamarker&lt;m&gt;:SGRam:Y:TRIGger</code> .....	136

**CALCulate<n>:DELTamarker<m>:SGRam:FRAMe <Frame> | <Time>**

This command positions the delta marker on a particular frame. The frame is relative to the position of marker 1.

The command is available for the spectrogram.

**Suffix:**

<n>	1...4	Selects the measurement window.
<m>	1...16	Selects the marker.

**Parameters:**

<Frame>   <Time>	<b>&lt;Frame&gt; (if time stamp is off)</b> Defines the distance of the deltamarker in frames and in relation to the position of marker 1.
	<b>&lt;time&gt; (if time stamp is on)</b> Defines the distance of the deltamarker in seconds and in relation to the position of marker 1. The reference is the time stamp of marker 1.

**Example:**

```
CALC:DELT4:SGR:FRAM -20
```

Sets fourth deltamarker 20 frames below marker 1.

```
CALC:DELT4:SGR:FRAM 2 s
```

Sets fourth deltamarker 2 seconds above the position of marker 1.

**CALCulate<n>:DELTamarker<m>:SGRam:SARea <SearchArea>**

This command defines the deltamarker search area.

The command is available for the spectrogram.

**Suffix:**

<n>	1...4	Selects the measurement window.
<m>	1...16	Selects the marker.

**Parameters:**

<SearchArea>	<b>VISible</b> Performs a search in the visible frames. Note that VISible is ignored if Spectrogram is not visible for any reason (e.g. if the Spectrum Analyzer is in full screen mode or display update is inactive).
	<b>MEMory</b> Performs a search over all frames in the memory. *RST: VISible

**Example:**

```
CALC:DELT:SGR:SAR MEM
```

Performs a search over all frames in the memory.

**CALCulate<n>:DELTamarker<m>:SGRam:XY:MAXimum[:PEAK]**

This command positions the specified delta marker on the current peak level of the spectrogram. The possible position depends on the deltamarker search area.

The command is available for the spectrogram.

For more information, see [CALCulate<n>:DELTamarker<m>:SGRam:SARea](#) on page 131.

**Suffix:**

<n> 1...4  
Selects the measurement window.

<m> 1...16  
Selects the marker.

**Example:**

```
CALC:DELT2:SGR: SAR VIS
CALC:DELT2:SGR: XY:MAX
```

Activates and positions delta marker 2 on the peak level in the visible Spectrogram.

**Usage:** Event

**CALCulate<n>:DELTamarker<m>:SGRam:XY:MINimum[:PEAK]**

This command positions the specified delta marker on the current minimum level of the spectrogram. The possible position depends on the deltamarker search area.

The command is available for the spectrogram.

For more information, see [CALCulate<n>:DELTamarker<m>:SGRam:SARea](#) on page 131.

**Suffix:**

<n> 1...4  
Selects the measurement window.

<m> 1...16  
Selects the marker.

**Example:**

```
CALC:DELT3:SGR: SAR VIS
CALC:DELT3:SGR: XY:MIN
```

Activates and positions delta marker 3 on the minimum level in the visible Spectrogram.

**Usage:** Event

**CALCulate<n>:DELTamarker<m>:SGRam:Y:MAXimum:ABOVE**

This command positions the specified delta marker on the next peak level of the vertical axis. The search includes only frames above the current marker position. It does not change the horizontal position of the delta marker.

The command is available for the spectrogram.

<b>Suffix:</b>	
<n>	1...4 Selects the measurement window.
<m>	1...16 Selects the marker.
<b>Example:</b>	<p><code>CALC:DELT2:SGR:Y:MAX</code> Activates and positions delta marker 2 on the peak level of the y-axis.</p> <p><code>CALC:DELT2:SGR:Y:MAX:ABOV</code> Positions delta marker 2 on the next higher level found in the diagram area above the current marker position.</p>
<b>Usage:</b>	Event

#### **CALCulate<n>:DELTamarker<m>:SGRam:Y:MAXimum:BELOW**

This command positions the specified delta marker on the next peak level of the vertical axis. The search includes only frames below the current marker position. It does not change the horizontal position of the delta marker.

The command is available for the spectrogram.

<b>Suffix:</b>	
<n>	1...4 Selects the measurement window.
<m>	1...16 Selects the marker.
<b>Example:</b>	<p><code>CALC:DELT2:SGR:Y:MAX</code> Activates and positions delta marker 2 on the peak level of the y-axis.</p> <p><code>CALC:DELT2:SGR:Y:MAX:BEL</code> Positions delta marker 2 on the next higher level found in the diagram area below the current marker position.</p>
<b>Usage:</b>	Event

#### **CALCulate<n>:DELTamarker<m>:SGRam:Y:MAXimum:NEXT**

This command positions the specified delta marker on the next peak level of the vertical axis. The search includes frames above and below the current marker position. It does not change the horizontal position of the delta marker.

The command is available for the spectrogram.

<b>Suffix:</b>	
<n>	1...4 Selects the measurement window.
<m>	1...16 Selects the marker.

**Example:**            `CALC:DELT2:SGR:Y:MAX`  
 Activates and positions delta marker 2 on the peak level of the y-axis.  
`CALC:DELT2:SGR:Y:MAX:NEXT`  
 Positions delta marker 2 on the next higher level.

**Usage:**            Event

#### **CALCulate<n>:DELTamarker<m>:SGRam:Y:MAXimum[:PEAK]**

This command positions the specified delta marker on the current peak level of the vertical axis. The search is performed over all frames. It does not change the horizontal position of the deltamarker.

The command is available for the spectrogram.

**Suffix:**

<n>                    1...4  
 Selects the measurement window.

<m>                    1...16  
 Selects the marker.

**Example:**            `CALC:DELT2:SGR:Y:MAX`  
 Activates and positions delta marker 2 on the peak level of the y-axis.

**Usage:**            Event

#### **CALCulate<n>:DELTamarker<m>:SGRam:Y:MINimum:ABOVe**

This command positions the specified delta marker on the next minimum level of the vertical axis. The search includes only frames above the current marker position. It does not change the horizontal position of the delta marker.

The command is available for the spectrogram.

**Suffix:**

<n>                    1...4  
 Selects the measurement window.

<m>                    1...16  
 Selects the marker.

**Example:**            `CALC:DELT2:SGR:Y:MIN`  
 Activates and positions delta marker 2 on the minimum level of the y-axis.

`CALC:DELT2:SGR:Y:MIN:ABOV`

Positions delta marker 2 on the next minimum level found in the diagram area above the current marker position.

**Usage:**            Event

**CALCulate<n>:DELTamarker<m>:SGRam:Y:MINimum:BELOW**

This command positions the specified delta marker on the next minimum level of the vertical axis. The search includes only frames below the current marker position. It does not change the horizontal position of the delta marker.

The command is available for the spectrogram.

**Suffix:**

<n> 1...4  
Selects the measurement window.

<m> 1...16  
Selects the marker.

**Example:**

`CALC:DELT2:SGR:Y:MIN`

Activates and positions delta marker 2 on the minimum level of the y-axis.

`CALC:DELT2:SGR:Y:MAX:BEL`

Positions delta marker 2 on the next minimum level found in the diagram area below the current marker position.

**Usage:** Event

**CALCulate<n>:DELTamarker<m>:SGRam:Y:MINimum:NEXT**

This command positions the specified delta marker on the next minimum level of the vertical axis. The search includes frames above and below the current marker position. It does not change the horizontal position of the delta marker.

The command is available for the spectrogram.

**Suffix:**

<n> 1...4  
Selects the measurement window.

<m> 1...16  
Selects the marker.

**Example:**

`CALC:DELT2:SGR:Y:MIN`

Activates and positions delta marker 2 on the minimum level of the y-axis.

`CALC:DELT2:SGR:Y:MIN:NEXT`

Positions delta marker 2 on the next minimum level.

**Usage:** Event

**CALCulate<n>:DELTamarker<m>:SGRam:Y:MINimum[:PEAK]**

This command positions the specified delta marker on the current minimum level of the vertical axis. The search is performed over all captured frames. It does not change the horizontal position of the delta marker.

The command is available for the spectrogram.

<b>Suffix:</b>	
<n>	1...4 Selects the measurement window.
<m>	1...16 Selects the marker.
<b>Example:</b>	<code>CALC:DELT2:SGR:Y:MIN</code> Activates and positions delta marker 2 on the minimum level of the y-axis.
<b>Usage:</b>	Event

---

#### **CALCulate<n>:DELTaMarker<m>:SGRaM:Y:TRIGger**

This command positions a marker in the spectrogram on the most recent trigger event.

<b>Suffix:</b>	
<n>	1...4 Selects the measurement window.
<b>Usage:</b>	Event

#### 6.4.2.6 Using the Marker Search

<a href="#">CALCulate&lt;n&gt;:MARKer&lt;m&gt;:X:SLIMits:LEFT</a> .....	136
<a href="#">CALCulate&lt;n&gt;:MARKer&lt;m&gt;:X:SLIMits:RIGHT</a> .....	137
<a href="#">CALCulate&lt;n&gt;:MARKer&lt;m&gt;:X:SLIMits[:STATe]</a> .....	137
<a href="#">CALCulate&lt;n&gt;:MARKer&lt;m&gt;:X:SLIMits:ZOOM</a> .....	138
<a href="#">CALCulate&lt;n&gt;:THReshold</a> .....	138
<a href="#">CALCulate&lt;n&gt;:THReshold:STATe</a> .....	138

---

#### **CALCulate<n>:MARKer<m>:X:SLIMits:LEFT <Limit>**

This command sets the left limit of the marker search range.

If the power measurement in zero span is active, this command limits the evaluation range to the trace.

**Note:** The function is only available if the search limit for marker and delta marker is switched on (see `CALCulate<n>:MARKer<m>:X:SLIMits[:STATe]`).

<b>Suffix:</b>	
<n>	Selects the measurement window.
<m>	irrelevant
<b>Parameters:</b>	
<Limit>	The value range depends on the span or sweep time. The unit is Hz for frequency domain measurements and s for time domain measurements.
	Range: 0 to MAX
	*RST: left diagram border



**Example:**            `CALC:MARK:X:SLIM ON`  
                          Switches the search limit function on.  
                          `CALC:MARK:X:SLIM:LEFT 10MHz`  
                          Sets the left limit of the search range to 10 MHz.

#### **CALCulate<n>:MARKer<m>:X:SLIMits:RIGHT <Limit>**

This command sets the right limit of the marker search range.

If the power measurement in zero span is active, this command limits the evaluation range to the trace.

**Note:** The function is only available if the search limit for marker and delta marker is switched on ( `CALCulate<n>:MARKer<m>:X:SLIMits[:STATe]` ).

#### **Suffix:**

<n>                    Selects the measurement window.  
 <m>                    irrelevant

#### **Parameters:**

<Limit>              The value range depends on the span or sweep time.  
                          The unit is Hz for frequency domain measurements and s for time domain measurements.  
                          Range:        0 to MAX  
                          \*RST:        left diagram border

**Example:**            `CALC:MARK:X:SLIM ON`  
                          Switches the search limit function on.  
                          `CALC:MARK:X:SLIM:RIGH 20MHz`  
                          Sets the right limit of the search range to 20 MHz.

#### **CALCulate<n>:MARKer<m>:X:SLIMits[:STATe] <State>**

This command turns marker search limits on and off.

If the power measurement in zero span is active, this command limits the evaluation range on the trace.

#### **Suffix:**

<n>                    Selects the measurement window.  
 <m>                    marker

#### **Parameters:**

<State>              ON | OFF  
                          \*RST:        OFF

**Example:**            `CALC:MARK:X:SLIM ON`  
                          Switches on search limitation.

**CALCulate<n>:MARKer<m>:X:SLIMits:ZOOM <State>**

This command sets the limits of the marker search range to the zoom area.

**Note:** The function is only available if the search limit for marker and delta marker is switched on (see `CALCulate<n>:MARKer<m>:X:SLIMits[:STATe]`).

**Suffix:**

<n> irrelevant

<m> irrelevant

**Parameters:**

<State> ON | OFF

\*RST: OFF

**Example:**

`CALC:MARK:X:SLIM:ZOOM ON`

Switches the search limit function on.

`CALC:MARK:X:SLIM:RIGH 20MHz`

Sets the right limit of the search range to 20 MHz.

**CALCulate<n>:THReshold <Threshold>**

This command defines a threshold value for the marker peak search.

A threshold line is automatically turned on.

**Suffix:**

<n> irrelevant

**Parameters:**

<Threshold> The unit depends on `CALCulate<n>:UNIT:POWer`.

\*RST: (STATe to OFF)

**Example:**

`CALC:THR -82DBM`

Sets the threshold value to -82 dBm.

**CALCulate<n>:THReshold:STATe <State>**

This command turns the threshold line for the marker peak search on and off.

**Suffix:**

<n> irrelevant

**Parameters:**

<State> ON | OFF

\*RST: OFF

**Example:**

`CALC:THR:STAT ON`

Switches on the threshold line.

## 6.5 Status Registers

The status reporting system stores information about the current state of the R&S ESR. This includes, for example, information about errors during operation or information about limit checks. The R&S ESR stores this information in the status registers and in the error queue. You can query the status register and error queue via IEC bus.

The R&S ESR-K40 features several status registers that are specific to phase noise measurements. Here is a description of those, including the corresponding remote commands.

- [Structure of a SCPI Status Register](#)..... 139
- [Contents of the Status Register](#)..... 140
- [Status Register](#)..... 144

### 6.5.1 Structure of a SCPI Status Register

Each standard SCPI register consists of 5 parts. Each part has a width of 16 bits and has different functions. The individual bits are independent of each other, i.e. each hardware status is assigned a bit number which is valid for all five parts. Bit 15 (the most significant bit) is set to zero for all parts. Thus the contents of the register parts can be processed by the controller as positive integers.

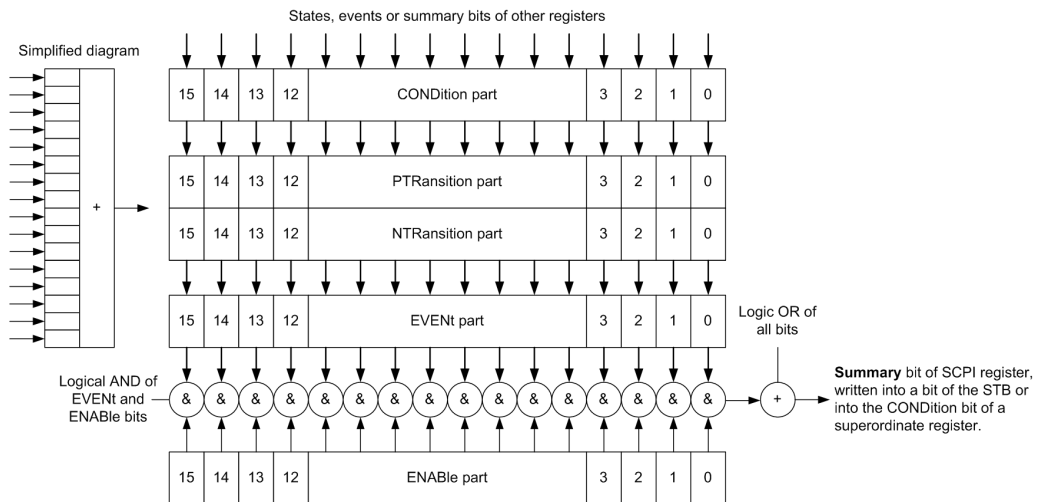

Fig. 6-1: The status-register model

#### Description of the five status register parts

The five parts of a SCPI register have different properties and functions:

- **CONDition**  
The CONDition part is written into directly by the hardware or the sum bit of the next lower register. Its contents reflect the current instrument status. This register part can only be read, but not written into or cleared. Its contents are not affected by reading.
- **PTRansition / NTRansition**

The two transition register parts define which state transition of the `CONDition` part (none, 0 to 1, 1 to 0 or both) is stored in the `EVENT` part.

The **Positive-TRansition** part acts as a transition filter. When a bit of the `CONDition` part is changed from 0 to 1, the associated `PTR` bit decides whether the `EVENT` bit is set to 1.

- `PTR` bit =1: the `EVENT` bit is set.
- `PTR` bit =0: the `EVENT` bit is not set.

This part can be written into and read as required. Its contents are not affected by reading.

The **Negative-TRansition** part also acts as a transition filter. When a bit of the `CONDition` part is changed from 1 to 0, the associated `NTR` bit decides whether the `EVENT` bit is set to 1.

- `NTR` bit =1: the `EVENT` bit is set.
- `NTR` bit =0: the `EVENT` bit is not set.

This part can be written into and read as required. Its contents are not affected by reading.

- **EVENT**

The `EVENT` part indicates whether an event has occurred since the last reading, it is the "memory" of the condition part. It only indicates events passed on by the transition filters. It is permanently updated by the instrument. This part can only be read by the user. Reading the register clears it. This part is often equated with the entire register.

- **ENABLE**

The `ENABLE` part determines whether the associated `EVENT` bit contributes to the sum bit (see below). Each bit of the `EVENT` part is "ANDed" with the associated `ENABLE` bit (symbol '&'). The results of all logical operations of this part are passed on to the sum bit via an "OR" function (symbol '+').

`ENABLE` bit = 0: the associated `EVENT` bit does not contribute to the sum bit

`ENABLE` bit = 1: if the associated `EVENT` bit is "1", the sum bit is set to "1" as well.

This part can be written into and read by the user as required. Its contents are not affected by reading.

### Sum bit

The sum bit is obtained from the `EVENT` and `ENABLE` part for each register. The result is then entered into a bit of the `CONDition` part of the higher-order register.

The instrument automatically generates the sum bit for each register. Thus an event can lead to a service request throughout all levels of the hierarchy.

## 6.5.2 Contents of the Status Register

This chapter provides information on the contents of each status register the meaning for all bits that are used available for each operating mode.

### 6.5.2.1 Status Register in Realtime Mode

This chapter contains the description of the registers and bits available in realtime mode. For a comprehensive description of the other status registers see the manual of the R&S ESR.

The figure below shows the status registers available in realtime mode.



You can read out the state of the register with `STATus:OPERation:CONDition?` or `STATus:OPERation[:EVENT]?`.

**Table 6-1: Meaning of the bits used in the STATus:OPERation register**

Bit No.	Meaning
0	CALibrating This bit is set as long as the instrument is performing a calibration.
1 to 7	Not used
8	HardCOpy in progress This bit is set while the instrument is printing a hardcopy.
9 to 14	Not used
15	This bit is always 0.

### STATus:QUEStionable Register

The STATus:QUEStionable register contains information about states that may occur if the R&S ESR is operated without meeting the specifications.

You can read out the state of the register with `STATus:QUEStionable:CONDition?` and `STATus:QUEStionable[:EVENT]?`.

**Table 6-2: Meaning of the bits used in the STATus:QUEStionable register**

Bit No.	Meaning
0 - 2	These bits are not used
2	TIME This bit is set if a
3	POWer This bit is set if a questionable power occurs (see the STATus:QUEStionable:POWer register in the manual of the R&S ESR).
4	TEMPerature This bit is set if a questionable temperature occurs.
5	FREQuency The bit is set if a frequency is questionable (see the STATus:QUEStionable:FREQuency register in the manual of the R&S ESR).
6 - 7	Not used
8	CALibration The bit is set if a measurement is performed unaligned ("UNCAL" display)
9	LIMit (device-specific) This bit is set if a limit value is violated (see the STATus:QUEStionable:LIMit register in the manual of the R&S ESR)
10	LMARgin (device-specific) This bit is set if a margin is violated (see the STATus:QUEStionable:LMARgin register in the manual of the R&S ESR)

Bit No.	Meaning
11 - 14	Not used
15	This bit is always 0.

### STATus:QUEStionable:TIME Register

The STATus:QUEStionable:TIME register contains information about possible errors in realtime mode.

You can read out the register with `STATus:QUEStionable:TIME:CONDition?` or `STATus:QUEStionable:TIME[:EVENT]?`.

*Table 6-3: Meaning of the bits used in the STATus:QUEStionable:TIME register*

Bit No.	Meaning
0	Real Time Data Loss This bit is set if the R&S ESR loses data during the measurement and measurements are no longer possible in realtime.
1 to 14	Unused
15	This bit is always 0.

## 6.5.3 Status Register

For more information on the contents of the status registers see the following sections.

Status registers exclusive to the realtime application.

- "`STATus:OPERation Register`" on page 142
- "`STATus:QUEStionable Register`" on page 143
- "`STATus:QUEStionable:TIME Register`" on page 144

Status registers explained in the manual of the R&S ESR.

- STATus:QUEStionable:FREQuency Register
- STATus:QUEStionable:LIMit Register
- STATus:QUEStionable:LMARgin Register
- STATus:QUEStionable:POWER Register

### 6.5.3.1 General Status Register Commands

<code>STATus:PRESet</code> .....	145
<code>STATus:QUEue[:NEXT]?</code> .....	145



**STATus:PRESet**

This command resets the edge detectors and ENABLE parts of all registers to a defined value. All PTRansition parts are set to FFFFh, i.e. all transitions from 0 to 1 are detected. All NTRansition parts are set to 0, i.e. a transition from 1 to 0 in a CONDition bit is not detected. The ENABLE part of the STATus:OPERation and STATus:QUEStionable registers are set to 0, i.e. all events in these registers are not passed on.

**Example:** STAT:PRES

**Usage:** SCPI confirmed

**STATus:QUEue[:NEXT?]?**

This command queries the earliest error queue entry and deletes it.

Positive error numbers indicate device-specific errors, negative error numbers are error messages defined by SCPI. If the error queue is empty, the error number 0, "No error", is returned. This command is identical to the `SYSTEM:ERROR[:NEXT]` command.

**Example:** STAT:QUES?

**Usage:** Query only  
SCPI confirmed

**6.5.3.2 Reading out the EVENT Part**

For more information on the event part see [chapter 6.5.1, "Structure of a SCPI Status Register"](#), on page 139.

**STATus:OPERation[:EVENT]?  
STATus:QUEStionable[:EVENT]?  
STATus:QUEStionable:FREQuency[:EVENT]?  
STATus:QUEStionable:LIMit<n>[:EVENT]?  
STATus:QUEStionable:LMARgin<n>[:EVENT]?  
STATus:QUEStionable:POWEr[:EVENT]?  
STATus:QUEStionable:TIME[:EVENT]?**

These commands read out the EVENT section of the status register.

At the same time, the commands delete the contents of the EVENT section.

**Usage:** Query only

**6.5.3.3 Reading Out the CONDition Part**

For more information on the condition part see [chapter 6.5.1, "Structure of a SCPI Status Register"](#), on page 139.

**STATus:OPERation:CONDition?  
STATus:QUEStionable:CONDition?  
STATus:QUEStionable:FREQuency:CONDition?  
STATus:QUEStionable:LIMit<n>:CONDition?**

**STATus:QUESTionable:LMARgin<n>:CONDition?**  
**STATus:QUESTionable:POWer:CONDition?**  
**STATus:QUESTionable:TIME:CONDition?**

These commands read out the CONDition section of the status register.

The commands do not delete the contents of the EVENT section.

**Usage:** Query only

#### 6.5.3.4 Controlling the ENABLE Part

For more information on the enable part see [chapter 6.5.1, "Structure of a SCPI Status Register"](#), on page 139.

---

**STATus:OPERation:ENABLE** <SumBit>  
**STATus:QUESTionable:ENABLE** <SumBit>  
**STATus:QUESTionable:FREQuency:ENABLE** <SumBit>  
**STATus:QUESTionable:LIMit<n>:ENABLE** <SumBit>  
**STATus:QUESTionable:LMARgin<n>:ENABLE** <SumBit>  
**STATus:QUESTionable:POWer:ENABLE** <SumBit>  
**STATus:QUESTionable:TIME:ENABLE** <SumBit>

These commands control the ENABLE part of a register.

The ENABLE part allows true conditions in the EVENT part of the status register to be reported in the summary bit. If a bit is 1 in the enable register and its associated event bit transitions to true, a positive transition will occur in the summary bit reported to the next higher level.

**Parameters:**

<SumBit> Range: 0 to 65535

#### 6.5.3.5 Controlling the Negative Transition Part

For more information on the positive transition part see [chapter 6.5.1, "Structure of a SCPI Status Register"](#), on page 139.

---

**STATus:OPERation:NTRansition** <SumBit>  
**STATus:QUESTionable:NTRansition** <SumBit>  
**STATus:QUESTionable:FREQuency:NTRansition** <SumBit>  
**STATus:QUESTionable:LIMit<n>:NTRansition** <SumBit>  
**STATus:QUESTionable:LMARgin<n>:NTRansition** <SumBit>  
**STATus:QUESTionable:POWer:NTRansition** <SumBit>  
**STATus:QUESTionable:TIME:NTRansition** <SumBit>

These commands control the Negative TRansition part of a register.

Setting a bit causes a 1 to 0 transition in the corresponding bit of the associated register. The transition also writes a 1 into the associated bit of the corresponding EVENT register.

**Parameters:**

<SumBit> Range: 0 to 65535

### 6.5.3.6 Controlling the Positive Transition Part

For more information on the negative transition part see [chapter 6.5.1, "Structure of a SCPI Status Register"](#), on page 139.

---

**STATus:OPERation:PTRansition** <SumBit>  
**STATus:QUEStionable:PTRansition** <SumBit>  
**STATus:QUEStionable:FREQuency:PTRansition** <SumBit>  
**STATus:QUEStionable:LIMit<n>:PTRansition** <SumBit>  
**STATus:QUEStionable:LMARgin<n>:PTRansition** <SumBit>  
**STATus:QUEStionable:POWer:PTRansition** <SumBit>  
**STATus:QUEStionable:TIME:PTRansition** <SumBit>

These commands control the Positive TRansition part of a register.

Setting a bit causes a 0 to 1 transition in the corresponding bit of the associated register. The transition also writes a 1 into the associated bit of the corresponding EVENT register.

**Parameters:**

<SumBit>                      Range:      0 to 65535

## List of Commands

CALCulate<n>:DELTamarker<m>:LINK.....	112
CALCulate<n>:DELTamarker<m>:MAXimum:LEFT.....	127
CALCulate<n>:DELTamarker<m>:MAXimum:NEXT.....	127
CALCulate<n>:DELTamarker<m>:MAXimum:RIGHT.....	128
CALCulate<n>:DELTamarker<m>:MAXimum[:PEAK].....	128
CALCulate<n>:DELTamarker<m>:MINimum:LEFT.....	129
CALCulate<n>:DELTamarker<m>:MINimum:NEXT.....	129
CALCulate<n>:DELTamarker<m>:MINimum:RIGHT.....	130
CALCulate<n>:DELTamarker<m>:MINimum[:PEAK].....	129
CALCulate<n>:DELTamarker<m>:MODE.....	112
CALCulate<n>:DELTamarker<m>:MREF.....	113
CALCulate<n>:DELTamarker<m>:SGRam:FRAME.....	131
CALCulate<n>:DELTamarker<m>:SGRam:SARea.....	131
CALCulate<n>:DELTamarker<m>:SGRam:XY:MAXimum[:PEAK].....	132
CALCulate<n>:DELTamarker<m>:SGRam:XY:MINimum[:PEAK].....	132
CALCulate<n>:DELTamarker<m>:SGRam:Y:MAXimum:ABOVE.....	132
CALCulate<n>:DELTamarker<m>:SGRam:Y:MAXimum:BELOW.....	133
CALCulate<n>:DELTamarker<m>:SGRam:Y:MAXimum:NEXT.....	133
CALCulate<n>:DELTamarker<m>:SGRam:Y:MAXimum[:PEAK].....	134
CALCulate<n>:DELTamarker<m>:SGRam:Y:MINimum:ABOVE.....	134
CALCulate<n>:DELTamarker<m>:SGRam:Y:MINimum:BELOW.....	135
CALCulate<n>:DELTamarker<m>:SGRam:Y:MINimum:NEXT.....	135
CALCulate<n>:DELTamarker<m>:SGRam:Y:MINimum[:PEAK].....	135
CALCulate<n>:DELTamarker<m>:SGRam:Y:TRIGger.....	136
CALCulate<n>:DELTamarker<m>:TRACe.....	113
CALCulate<n>:DELTamarker<m>:X.....	114
CALCulate<n>:DELTamarker<m>:X:RELative.....	114
CALCulate<n>:DELTamarker<m>:Y.....	115
CALCulate<n>:DELTamarker<m>:Z?.....	115
CALCulate<n>:DELTamarker<m>[:STATe].....	113
CALCulate<n>:FEED.....	72
CALCulate<n>:MARKer<m>:AOFF.....	108
CALCulate<n>:MARKer<m>:FUNCTion:CENTer.....	116
CALCulate<n>:MARKer<m>:FUNCTion:REFerence.....	116
CALCulate<n>:MARKer<m>:FUNCTion:ZOOM.....	108
CALCulate<n>:MARKer<m>:LOEXclude.....	109
CALCulate<n>:MARKer<m>:MAXimum:AUTO.....	117
CALCulate<n>:MARKer<m>:MAXimum:LEFT.....	117
CALCulate<n>:MARKer<m>:MAXimum:NEXT.....	118
CALCulate<n>:MARKer<m>:MAXimum:RIGHT.....	118
CALCulate<n>:MARKer<m>:MAXimum[:PEAK].....	118
CALCulate<n>:MARKer<m>:MINimum:AUTO.....	119
CALCulate<n>:MARKer<m>:MINimum:LEFT.....	119
CALCulate<n>:MARKer<m>:MINimum:NEXT.....	120
CALCulate<n>:MARKer<m>:MINimum:RIGHT.....	121

CALCulate<n>:MARKer<m>:MINimum[:PEAK].....	120
CALCulate<n>:MARKer<m>:SGRam:FRAMe.....	121
CALCulate<n>:MARKer<m>:SGRam:SARea.....	122
CALCulate<n>:MARKer<m>:SGRam:XY:MAXimum[:PEAK].....	122
CALCulate<n>:MARKer<m>:SGRam:XY:MINimum[:PEAK].....	123
CALCulate<n>:MARKer<m>:SGRam:Y:MAXimum:ABOVE.....	123
CALCulate<n>:MARKer<m>:SGRam:Y:MAXimum:BELOW.....	124
CALCulate<n>:MARKer<m>:SGRam:Y:MAXimum:NEXT.....	124
CALCulate<n>:MARKer<m>:SGRam:Y:MAXimum[:PEAK].....	125
CALCulate<n>:MARKer<m>:SGRam:Y:MINimum:ABOVE.....	125
CALCulate<n>:MARKer<m>:SGRam:Y:MINimum:BELOW.....	125
CALCulate<n>:MARKer<m>:SGRam:Y:MINimum:NEXT.....	126
CALCulate<n>:MARKer<m>:SGRam:Y:MINimum[:PEAK].....	126
CALCulate<n>:MARKer<m>:SGRam:Y:TRIGger.....	127
CALCulate<n>:MARKer<m>:TRACe.....	109
CALCulate<n>:MARKer<m>:X.....	110
CALCulate<n>:MARKer<m>:X:SLIMits:LEFT.....	136
CALCulate<n>:MARKer<m>:X:SLIMits:RIGHT.....	137
CALCulate<n>:MARKer<m>:X:SLIMits:ZOOM.....	138
CALCulate<n>:MARKer<m>:X:SLIMits[:STATe].....	137
CALCulate<n>:MARKer<m>:X:SSIZe.....	110
CALCulate<n>:MARKer<m>:Y.....	111
CALCulate<n>:MARKer<m>:Z?.....	112
CALCulate<n>:MARKer<m>[:STATe].....	109
CALCulate<n>:MASK:CDIRectory.....	99
CALCulate<n>:MASK:COMMeNt.....	99
CALCulate<n>:MASK:DELeTe.....	99
CALCulate<n>:MASK:LOWer:SHIFt:X.....	99
CALCulate<n>:MASK:LOWer:SHIFt:Y.....	100
CALCulate<n>:MASK:LOWer[:DATA].....	100
CALCulate<n>:MASK:LOWer[:STATe].....	100
CALCulate<n>:MASK:MODE.....	101
CALCulate<n>:MASK:NAME.....	101
CALCulate<n>:MASK:SPAN.....	101
CALCulate<n>:MASK:UPPer:AUTO.....	101
CALCulate<n>:MASK:UPPer:SHIFt:X.....	101
CALCulate<n>:MASK:UPPer:SHIFt:Y.....	102
CALCulate<n>:MASK:UPPer[:DATA].....	102
CALCulate<n>:MASK:UPPer[:STATe].....	102
CALCulate<n>:SGRam:CLEAr[:IMMeDiate].....	77
CALCulate<n>:SGRam:CLEAr[:IMMeDiate].....	91
CALCulate<n>:SGRam:CONT.....	77
CALCulate<n>:SGRam:CONT.....	91
CALCulate<n>:SGRam:FRAMe:COUNt.....	78
CALCulate<n>:SGRam:FRAMe:COUNt.....	91
CALCulate<n>:SGRam:FRAMe:SELeCt.....	78
CALCulate<n>:SGRam:FRAMe:SELeCt.....	92
CALCulate<n>:SGRam:HDEPth.....	79

CALCulate<n>:SGRam:TSTamp:DATA?	79
CALCulate<n>:SGRam:TSTamp[:STATe]	80
CALCulate<n>:SGRam:X:DATA?	80
CALCulate<n>:SGRam[:STATe]	80
CALCulate<n>:THReshold	138
CALCulate<n>:THReshold:STATe	138
CALCulate<n>:UNIT:POWER	86
DISPlay:MTABLE	115
DISPlay:WINDow:PSPectrum:COLor:DEFault	76
DISPlay:WINDow:PSPectrum:COLor:LOWer	76
DISPlay:WINDow:PSPectrum:COLor:SHAPE	76
DISPlay:WINDow:PSPectrum:COLor:TRUNcate	76
DISPlay:WINDow:PSPectrum:COLor:UPPer	76
DISPlay:WINDow:PSPectrum:COLor[:STYLe]	77
DISPlay:WINDow:SGRam:COLor:DEFault	81
DISPlay:WINDow:SGRam:COLor:LOWer	81
DISPlay:WINDow:SGRam:COLor:SHAPE	81
DISPlay:WINDow:SGRam:COLor:UPPer	82
DISPlay:WINDow:SGRam:COLor[:STYLe]	82
DISPlay:WINDow<n>[:SUBWIndow<m>]:TRACe:MAXHold[:STATe]	74
DISPlay:WINDow<n>[:SUBWIndow<m>]:TRACe<t>:MAXHold[:INTensity]	74
DISPlay:WINDow<n>[:SUBWIndow<m>]:TRACe<t>:PERSistence:DURation	74
DISPlay:WINDow<n>[:SUBWIndow<m>]:TRACe<t>:PERSistence[:STATe]	75
DISPlay:WINDow<n>[:SUBWIndow<m>]:TRACe<t>:SYMBOL	75
DISPlay:WINDow[:SUBWIndow]:TRACe:MAXHold:RESet	73
DISPlay:WINDow[:SUBWIndow]:TRACe:PERSistence:GRANularity	74
DISPlay:WINDow[:SUBWIndow]:ZOOM:AREA	72
DISPlay:WINDow[:SUBWIndow]:ZOOM:STATe	73
DISPlay[:WINDow<n>]:TRACe<t>:MODE	104
DISPlay[:WINDow<n>]:TRACe<t>:MODE:HCONTinuous	104
DISPlay[:WINDow<n>]:TRACe<t>:Y:SPACing	88
DISPlay[:WINDow<n>]:TRACe<t>:Y[:SCALE]	87
DISPlay[:WINDow<n>]:TRACe<t>:Y[:SCALE]:MODE	87
DISPlay[:WINDow<n>]:TRACe<t>:Y[:SCALE]:RLEVel	88
DISPlay[:WINDow<n>]:TRACe<t>:Y[:SCALE]:RLEVel:OFFSet	88
DISPlay[:WINDow<n>]:TRACe<t>[:STATe]	105
FORMat:DEXPort:DSEParator	106
FORMat[:DATA]	105
INITiate<n>:CONMeas	92
INITiate<n>:CONTInuous	93
INITiate<n>[:IMMediate]	93
INPut:ATTenuation	89
INPut:ATTenuation:AUTO	89
INPut:COUPling	89
INPut:GAIN:STATe	89
INPut:IMPedance	90
INSTRument:CREate[:NEW]	70
INSTRument:DELeTe	70

INSTRument[:SElect].....	71
MMEMory:STORe:SGRam.....	81
MMEMory:STORe<n>:TRACe.....	106
STATus:OPERation:CONDition?.....	145
STATus:OPERation:ENABle.....	146
STATus:OPERation:NTRansition.....	146
STATus:OPERation:PTRansition.....	147
STATus:OPERation[:EVENT]?.....	145
STATus:PRESet.....	145
STATus:QUESTionable:CONDition?.....	145
STATus:QUESTionable:ENABle.....	146
STATus:QUESTionable:FREQuency:CONDition?.....	145
STATus:QUESTionable:FREQuency:ENABle.....	146
STATus:QUESTionable:FREQuency:NTRansition.....	146
STATus:QUESTionable:FREQuency:PTRansition.....	147
STATus:QUESTionable:FREQuency[:EVENT]?.....	145
STATus:QUESTionable:LIMit<n>:CONDition?.....	145
STATus:QUESTionable:LIMit<n>:ENABle.....	146
STATus:QUESTionable:LIMit<n>:NTRansition.....	146
STATus:QUESTionable:LIMit<n>:PTRansition.....	147
STATus:QUESTionable:LIMit<n>[:EVENT]?.....	145
STATus:QUESTionable:LMARgin<n>:CONDition?.....	146
STATus:QUESTionable:LMARgin<n>:ENABle.....	146
STATus:QUESTionable:LMARgin<n>:NTRansition.....	146
STATus:QUESTionable:LMARgin<n>:PTRansition.....	147
STATus:QUESTionable:LMARgin<n>[:EVENT]?.....	145
STATus:QUESTionable:NTRansition.....	146
STATus:QUESTionable:POWer:CONDition?.....	146
STATus:QUESTionable:POWer:ENABle.....	146
STATus:QUESTionable:POWer:NTRansition.....	146
STATus:QUESTionable:POWer:PTRansition.....	147
STATus:QUESTionable:POWer[:EVENT]?.....	145
STATus:QUESTionable:PTRansition.....	147
STATus:QUESTionable:TIME:CONDition?.....	146
STATus:QUESTionable:TIME:ENABle.....	146
STATus:QUESTionable:TIME:NTRansition.....	146
STATus:QUESTionable:TIME:PTRansition.....	147
STATus:QUESTionable:TIME[:EVENT]?.....	145
STATus:QUESTionable[:EVENT]?.....	145
STATus:QUEEue[:NEXT]??.....	145
TRACe<n>:COPY.....	107
TRACe<n>[:DATA].....	107
TRIGger:MODE.....	95
TRIGger<n>[:SEQuence]:HOLDoff[:TIME].....	95
TRIGger<n>[:SEQuence]:MASK:CONDition.....	103
TRIGger<n>[:SEQuence]:SLOPe.....	95
TRIGger<n>[:SEQuence]:SOURce.....	96
TRIGger<n>[:SEQuence]:TDTRigger:LEVel.....	96

TRIGger[:SEQuence]:POSTtrigger[:TIME].....	97
TRIGger[:SEQuence]:PRETrigger[:TIME].....	97
[SENSe:]BANDwidth BWIDth[:RESolution].....	85
[SENSe:]BANDwidth BWIDth[:RESolution]:AUTO.....	86
[SENSe:]BANDwidth BWIDth[:RESolution]:RATio.....	86
[SENSe:]FREQuency:CENTer.....	83
[SENSe:]FREQuency:CENTer:STEP.....	83
[SENSe:]FREQuency:CENTer:STEP:LINK.....	84
[SENSe:]FREQuency:CENTer:STEP:LINK:FACTor.....	84
[SENSe:]FREQuency:OFFSet.....	84
[SENSe:]FREQuency:SPAN.....	84
[SENSe:]FREQuency:SPAN:FULL.....	85
[SENSe:]FREQuency:START.....	85
[SENSe:]FREQuency:STOP.....	85
[SENSe:]POWer:NCORrection.....	90
[SENSe:]SWEep:COUNT.....	94
[SENSe:]SWEep:TIME.....	94
[SENSe:]SWEep:TIME:AUTO.....	94
[SENSe:][WINDow:]DETEctor<trace>[:FUNCTion].....	106
[SENSe<n>]:SWEep:FFT:WINDow:TYPE.....	71



# Index

## A

ASCII Trace export .....	43
Attenuation	
Automatic .....	56
Manual .....	55, 89
Option B25 .....	55
Auto Peak detector .....	43
Average detector .....	43

## B

Blank trace mode .....	61
------------------------	----

## C

Clear Write trace mode .....	60
Color curve .....	20
Color Mapping .....	16
Color scheme .....	17
CONDition .....	139
Correction	
inherent noise .....	56

## D

detector	
overview .....	43
Detector	
Average .....	62
Negative Peak .....	62
Positive Peak .....	61
display range	
level .....	53, 54

## E

ENABLE .....	139
EVENT .....	139
export format .....	43
external trigger .....	59

## F

Frequency mask trigger .....	34
------------------------------	----

## H

HOME key .....	6
----------------	---

## I

Impedance	
Input .....	57
Inherent noise	
correction .....	56

## K

Key	
HOME .....	6
MODE .....	5

## L

level	
axis .....	55
display range .....	53, 54
range .....	53, 54
Level	
Reference .....	53
line	
threshold .....	68
LO exclude .....	69

## M

marker	
center frequency to .....	67
peak .....	66
reference level to .....	67
search limit .....	67
Markers	
Set to trace .....	64, 67
Marker to trigger .....	40
Marker Wizard	
softkey .....	64
Maxhold .....	27
Max Hold trace mode .....	60
maximum search .....	66
Measurement modes	
Changing .....	5
Displaying main menus .....	6
Min Hold trace mode .....	61
minimum search .....	67
Mode	
see also Measurement modes .....	5
MODE key .....	5

## N

Negative Peak detector .....	43
noise	
correction .....	56
NTRansition .....	139

## O

offset	
reference level .....	56
Options	
FSV-B25 .....	55
RF Preamplifier (B22) .....	55
Overwrite mode .....	60

## P

PEAKSEARCH .....	66
Persistence .....	26
Persistence spectrum	
color curve .....	20
color mapping .....	16
color scheme .....	17
maxhold .....	27
trace style .....	28
Positive Peak detector .....	43
Posttrigger .....	39

Preamplifier (B22) .....	55	dBpW .....	55
Pretrigger .....	39	Decim Sep .....	62
PTRansition .....	139	Detector Manual Select (remote control) .....	106
<b>R</b>		Deviation Lin/Log (remote control) .....	88
Realtime mode		Exclude LO (remote control) .....	109
color curve .....	20	External .....	59
color mapping .....	16	Fast ACLR On/Off (remote control) .....	90
color scheme .....	17	Free Run .....	58
external trigger .....	39	Full Span (remote control) .....	85
free run .....	39	Grid Abs/Rel .....	56
maxhold .....	27	Grid Abs/Rel (remote control) .....	87
persistence .....	26	Input 50 W/75 W (remote control) .....	90
posttrigger .....	39	Left Limit .....	68
pretrigger .....	39	Left Limit (remote control) .....	136
realtime bandwidth .....	33	Limits On/Off (remote control) .....	137
resolution bandwidth .....	34	Link Mrk1 and Delta1 (remote control) .....	112
span .....	33	Manual (remote control) .....	83
spectrogram .....	12	Marker 1, Marker 2 ...16 .....	63
sweep time .....	32	Marker 1 (remote control) .....	113
time domain trigger .....	39	Marker 1-16 .....	63
trace style .....	28	Marker 1 to 4 (remote control) .....	109, 110, 114, 115
trigger .....	34	Marker 2 (remote control) .....	113
reference		Marker 3 (remote control) .....	113
level to marker level .....	67	Marker 4 (remote control) .....	113
reference level		Marker Norm/Delta .....	63
offset .....	56	Marker Norm/Delta (remote control) .....	113
to marker level .....	67	Marker Stepsize .....	65
Reference level .....	53	Marker Stepsize (remote control) .....	110
Resolution bandwidth .....	34	Marker Table (Off/On/Aut) (remote control) .....	115
RF Preamplifier (B22) .....	55	Marker Table (On/Off) .....	65
RMS		Marker to Trace (remote control) .....	113
VBW .....	43	Marker Wizard .....	64
RMS detector .....	43	Marker Zoom (remote control) .....	108
<b>S</b>		Min .....	67
Sample detector .....	43	Min (remote control) .....	120, 129
scaling		More Markers .....	63
level axis .....	56	Next Min .....	67
search		Next Min (remote control) .....	119, 120, 121, 129
minimum .....	67	Next Mode </abs/> .....	68
peak .....	66	Next Peak .....	66
range .....	67	Next Peak (remote control) .....	117, 118, 119, 121, 127, 128, 129, 130
softkey		Noise Correction .....	56
0.1 * RBW (remote control) .....	84	Peak .....	66
0.1 * Span (remote control) .....	84	Peak (remote control) .....	118, 128
0.5 * RBW (remote control) .....	84	Range .....	53
0.5 * Span (remote control) .....	84	Range Lin. Unit .....	55
All Marker Off .....	65	Range Lin. Unit (remote control) .....	88
Ampere .....	55	Range Linear % .....	54
ASCII Trace Export .....	62	Range Linear % (remote control) .....	88
Auto Max Peak .....	67	Range Log (remote control) .....	87, 88
Auto Max Peak (remote control) .....	117	Range Log 100 dB .....	53
Auto Min Peak .....	67	Range Log 10 dB .....	54
Auto Min Peak (remote control) .....	119	Range Log 1 dB .....	54
Center =Mkr Freq .....	67	Range Log 50 dB .....	53
Center =Mkr Freq (remote control) .....	116	Range Log 5 dB .....	54
CF Stepsize (remote control) .....	83	Range Log Manual .....	54
Continue Single Sweep (remote control) .....	92	Ref Level Offset .....	56
Copy Trace .....	62	Ref Level Offset (remote control) .....	88
Copy Trace (remote control) .....	107	Ref Level Position .....	56
dB $\mu$ A .....	55	Ref Lvl =Mkr Lvl .....	67
dB $\mu$ V .....	55	Ref Lvl =Mkr Lvl (remote control) .....	116
dBm .....	55	Res BW (remote control) .....	85
dBmV .....	55	Res BW Auto (remote control) .....	86
		Res BW Manual (remote control) .....	85, 86
		Right Limit .....	68

- Right Limit (remote control) ..... 137
- Search Limits ..... 67
- Search Limits (remote control) ..... 137
- Search Lim Off ..... 68
- Search Lim Off (remote control) ..... 137, 138
- Select 1 2 3 4 (remote control) ..... 109
- Span Manual (remote control) ..... 84
- Start (remote control) ..... 85
- Start Frequency (remote control) ..... 85
- Stepsize Standard ..... 65
- Stepsize Standard (remote control) ..... 110
- Stepsize Sweep Points ..... 66
- Stepsize Sweep Points (remote control) ..... 110
- Stop (remote control) ..... 85
- Stop Frequency (remote control) ..... 85
- Sweptime Auto (remote control) ..... 94
- Threshold ..... 68
- Threshold (remote control) ..... 138
- Trace 1 2 3 4 5 6 (remote control) ..... 105
- Trace Mode (remote control) ..... 87
- Trg/Gate Polarity Pos/Neg (remote control) ..... 95
- Trigger Holdoff (remote control) ..... 95
- Unit ..... 55
- Unit (remote control) ..... 86
- Use Zoom Limits ..... 68
- Use Zoom Limits (remote control) ..... 138
- Volt ..... 55
- Watt ..... 55
- X \* RBW (remote control) ..... 84
- X \* Span (remote control) ..... 84
- Zero Span (remote control) ..... 84
- Softkey
  - Blank ..... 61
  - Center (remote control) ..... 83
  - Clear Write ..... 60
  - color mapping ..... 16
  - Continuous Sweep (remote control) ..... 93
  - continuous trigger ..... 40
  - Cont Meas (remote control) ..... 93
  - Decim Sep (remote control) ..... 106
  - Delete mask ..... 38
  - Exclude LO ..... 69
  - Frequency mask ..... 34
  - Frequency Offset (remote control) ..... 84
  - full span ..... 33
  - Input (AC/DC) ..... 57
  - Input (AC/DC)(remote control) ..... 89
  - Input 50  $\Omega$ /75  $\Omega$  ..... 57
  - Load mask ..... 38
  - Marker 1 to 4 (remote control) ..... 111
  - Marker to Trace ..... 64, 67
  - Marker to Trace (remote control) ..... 109
  - marker to trigger ..... 40
  - Max Hold ..... 60
  - maxhold intensity ..... 27
  - maxhold reset ..... 27
  - Mech Atten Auto ..... 56
  - Mech Atten Auto (remote control) ..... 89
  - Mech Atten Manual ..... 55
  - Mech Atten Manual (remote control) ..... 89
  - Min Hold ..... 61
  - New mask ..... 35
  - New Spectrum (remote control) ..... 70
  - persistence ..... 26
  - persistence granularity ..... 26
  - posttrigger ..... 39
  - Preamp On/Off ..... 55
  - Preamp On/Off (remote control) ..... 89
  - pretrigger ..... 39
  - Ref Level ..... 53
  - Ref Level (remote control) ..... 88
  - res BW ..... 34
  - RF Atten Auto ..... 56
  - RF Atten Auto (remote control) ..... 89
  - RF Atten Manual ..... 55
  - RF Atten Manual (remote control) ..... 89
  - Save (remote control) ..... 106
  - Save mask ..... 38
  - Select 1 2 3 4 (remote control) ..... 111
  - Single Meas (remote control) ..... 93
  - Single Sweep (remote control) ..... 93
  - span ..... 33
  - start frequency ..... 33
  - stop frequency ..... 33
  - stop on trigger ..... 40
  - style (vec dots) ..... 28
  - Sweep Count (remote control) ..... 94
  - Sweep Time (remote control) ..... 94
  - sweep time auto ..... 32
  - sweep time manual ..... 32
  - Sweptime Manual (remote control) ..... 94
  - time domain trigger ..... 39
  - Trace Mode (remote control) ..... 104
  - Trg/Gate Source (remote control) ..... 96
  - View ..... 61
- Softkeys
  - Detector Average ..... 62
  - Detector Negative Peak ..... 62
  - Detector Positive Peak ..... 61
- Span ..... 33
- Spectrogram
  - clear ..... 12
  - color curve ..... 20
  - color mapping ..... 16
  - color scheme ..... 17
  - frame count ..... 12
  - history ..... 12
  - realtime mode ..... 12
  - time stamp ..... 12
  - zoom ..... 14
- Status registers
  - CONDITION ..... 139
  - ENABLE ..... 139
  - EVENT ..... 139
  - model ..... 139
  - NTRansition ..... 139
  - parts ..... 139
  - PTRansition ..... 139
  - STATUS:OPERation ..... 142
  - STATUS:QUESTionable ..... 143
  - STATUS:QUESTionable:TIME ..... 144
- sweep
  - Free Run ..... 58
- Sweep time ..... 32
- T**
  - threshold
    - line ..... 68
  - Trace
    - Clear Write ..... 60

Trace mode	
Blank .....	61
Clear Write .....	60
Max Hold .....	60
Min Hold .....	61
View .....	61
Trace style .....	28
trigger	
external .....	59
Trigger (realtime mode) .....	34
trigger mode	
External .....	59
Free Run .....	58
<b>V</b>	
VBW	
RMS detector .....	43
View trace mode .....	61
<b>Z</b>	
Zoom .....	14
Amplitude .....	61